

UNIKA[®]
NATURSTEINWERK
5211 Lengau

Steinmetzmeisterbetrieb
Tel.: +43 (0)7746-2061
www.natursteine.at

WILD STONE[®]









Quality First - Beauty Forever

WILD STONE

STONE VENEER / VERBLENDSTEIN / KAMIEŃ DEKORACYJNY / KAMENNÝ OBKLAD

PANELISED MODELS / PANELMODELLE / MODELE PANELOWE / FORMÁTOVANÝ OBKLAD

SLANEC	6
ORNEL	8
MEROCK	10
MONTE NEGRO	14
CASTELO	16

INDIVIDUAL MODELS / INDIVIDUELLE MODELLE / MODELE INDYWIDUALNE / JEDNOTLIVÉ KAMENY

SPLIT SANDSTONE / GESPALTENER SANDSTEIN / ŠTÍPANÝ PÍSKOVEC	20
RIVER STONE / FLUSSSTEIN / ŘÍČNÍ KÁMEN	22
CASTLE WALL / BURGMAUER / HRADNÍ ZEĎ	26
BROCKEN ROCK / GEBROCHENES GESTEIN / LÁMANÁ SKÁLA	28
LIMESTONE / OPUKA	32
MIX ALPINA	34
MIX COLORADO	38
MIX RUSTICO	40
MIX GRIGIO	42
MIX TOSCANA	46
MIX COUNTRY	48
MIX TIROL	50
MIX DAVOS	54
MIX CARRARA	56

PORTLAND PAVEMENT / PORTLANDPFLASTER / BRUK PORTLADZKI / PORTLANDSKÁ DLAŽBA

BRICK VENEER / KLINKERRIEMCHEN / CEGŁA DEKORACYJNA / CIHLOVÉ PÁSKY

HOLLAND BRICK	74
CASTLE BRICK	76
MURA BRICK	78

ACCESORIES / ERGÄNZUNG / DODATKI / DOPLŇKY

EQUIPMENT / ZUBEHÖR / PRZYBORY / PŘÍSLUŠENSTVÍ

APPLICATION / MONTAGEVORGANG / PROCEDURY MONTAŽU / MONTÁŽNÍ POSTUPY

CERTIFIKATES / ZERTIFIKATE / CERTYFIKATY / CERTIFIKÁTY

MARKETING



***STONE VENEER
VERBLENDSTEIN
KAMIEŃ DEKORACYJNY
KAMENNÝ OBKLAD***

PANELISED MODELS / PANELMODELLE / MODELE PANELOWE / FORMÁTOVANÝ OBKLAD

SLANEC

SLANEC / SLANEC

PANELISED MODELS / PANELMODELLE / MODELE PANELOWE / FORMÁTOVANÝ OBKLAD

STONE VENEER / VERBLENDSTEIN / KAMIEŃ DEKORACYJNY / KAMENNÝ OBKLAD



002 - PYRAMID



003 - COLOSEUM



004 - BLEND CREAM

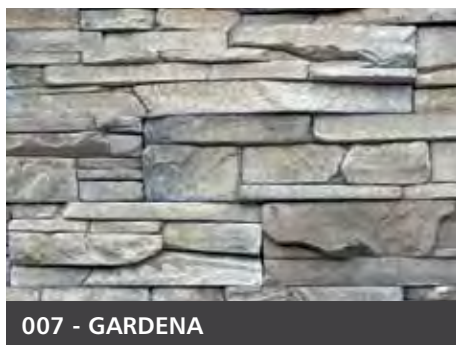

007 - GARDENA



008 - BASALT

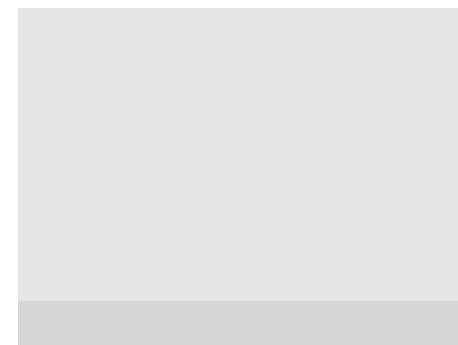



004 - BLEND CREAM

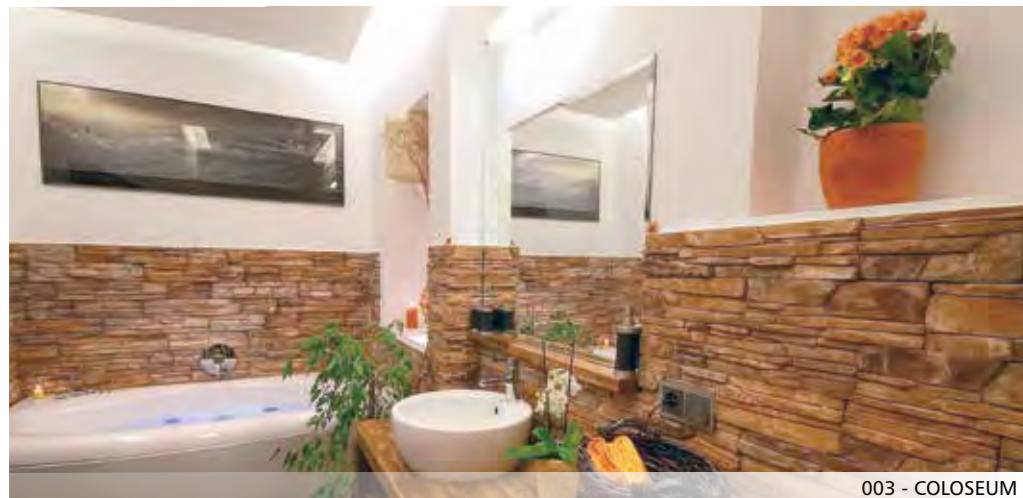

003 - COLOSEUM



$a = 200, 300, 500 \text{ mm} / b = 100 \text{ mm} / c = 10 - 28 \text{ mm}$

$d = 170 \text{ mm} / e = 80 \text{ mm}$

tolerance: 15 mm



$= 30 \text{ pcs/St/szt/ks}$

1 m²



$= 10 \text{ pcs/St/szt/ks}$

1 LM



$= 0,5 \text{ m}^2 = 16 \text{ kg} / 1 \text{ LM} = 9 \text{ kg}$



$= 40 \times 0,5 \text{ m}^2 = 20 \text{ m}^2 = 680 \text{ kg}$
 $40 \times 1 \text{ LM} = 40 \text{ LM} = 380 \text{ kg}$



PROFI BOX = 40 m²
 1100x1110x1200 mm

ADHESIVE / KLEBER / KLEJ / LEPIDLO

$= 8 \text{ kg/m}^2 // 3 \text{ kg/LM}$

HYDROFOBIZANT

$= 1/7 \text{ m}^2 // 1/21 \text{ LM}$

MORTAR / FUGENMÖRTEL

FUGA CEMENTOWA / SPÁROVACÍ HMOTA

NO JOINTS / NICHT VERFUGEN

BEZ FUGOWANIA / NESPÁRUJE SE

ORNEL

ORNEL / ORNEL

PANELISED MODELS / PANELMODELLE / MODELE PANELOWE / FORMÁTOVANÝ OBKLAD

STONE VENEER / VERBLENDSTEIN / KAMIEN DEKORACYJNY / KAMENNÝ OBKLAD



601 - VALENCIA

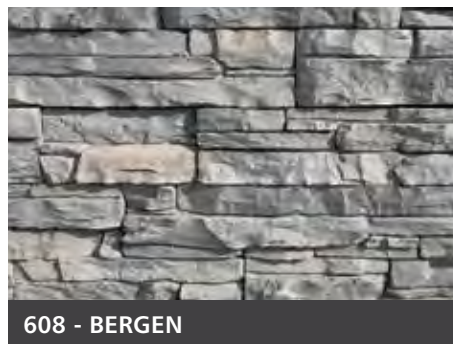

608 - BERGEN

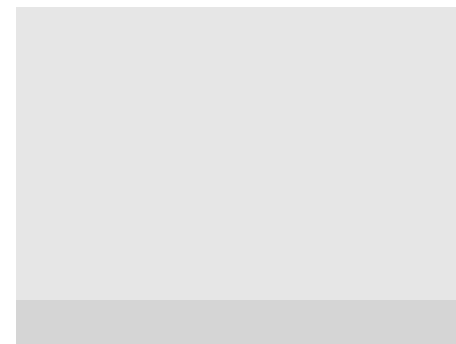

613 - COMO



624 - REFIDO



688 - NERRO



601 - VALENCIA



613 - COMO



608 - BERGEN



688 - NERRO



$a = 200, 300, 500 \text{ mm} / b = 100 \text{ mm} / c = 20 - 40 \text{ mm}$

$d = 200 \text{ mm} / e = 100 \text{ mm}$

tolerance: 15 mm



= 30 pcs/St/szt/ks



= 10 pcs/St/szt/ks

1 LM



= $0,4 \text{ m}^2 = 20 \text{ kg} / 1 \text{ LM} = 14 \text{ kg}$



= $40 \times 0,4 \text{ m}^2 = 16 \text{ m}^2 = 780 \text{ kg}$
 $40 \times 1 \text{ LM} = 40 \text{ LM} = 560 \text{ kg}$



PROFI BOX = 28 m^2
 $1100 \times 1110 \times 1200 \text{ mm}$

ADHESIVE / KLEBER / KLEJ / LEPIDLO

= $8 \text{ kg/m}^2 // 3 \text{ kg/LM}$

HYDROFOBIZANT

= $1/7 \text{ m}^2 // 1/21 \text{ LM}$

MORTAR / FUGENMÖRTEL

FUGA CEMENTOWA / SPÁROVACÍ HMOTA

NO JOINTS / NICHT VERFUGEN

BEZ FUGOWANIA / NESPÁRUJE SE

MEROCK

MEROCK / MEROCK

PANELISED MODELS / PANELMODELLE / MODELE PANELOWE / FORMÁTOVANÝ OBKLAD

STONE VENEER / VERBLENDSTEIN / KAMIEŃ DEKORACYJNY / KAMENNÝ OBKLAD

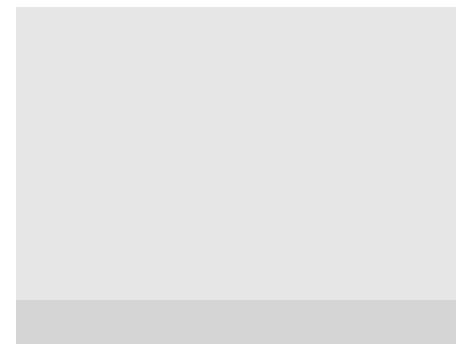
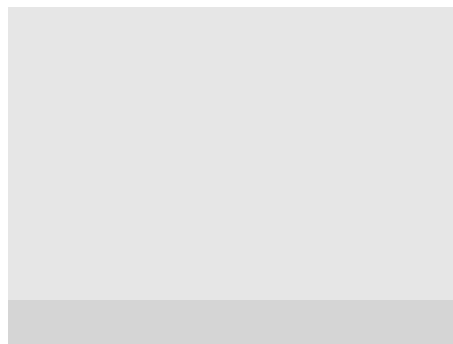
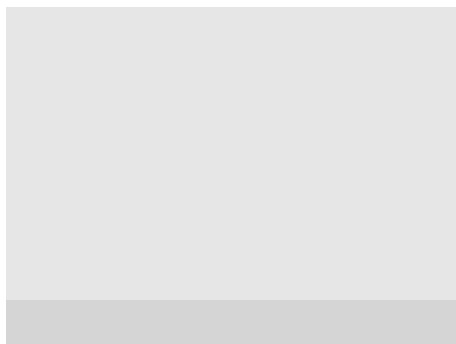

081 - SALAMANCA



082 - ZARAGOZA



086 - TARANTO



082 - ZARAGOZA



086 - TARANTO



086 - TARANTO



081 - SALAMANCA



$a = 200, 300, 500 \text{ mm} / b = 100 \text{ mm} / c = 10 - 28 \text{ mm}$

$d = 200, 300 \text{ mm} / e = 100 \text{ mm}$

tolerance: 15 mm



= 30 pcs/St/szt/ks

1 m²



= 10 pcs/St/szt/ks

1 LM



= 0,5 m² = 17 kg / 1 LM = 11 kg



= 40 x 0,5 m² = 20 m² = 720 kg
40 x 1 LM = 40 LM = 460 kg



PROFI BOX = 38 m²
1100x1110x1200 mm

ADHESIVE / KLEBER / KLEJ / LEPIDLO

= 8 kg/m² // 3 kg/LM

HYDROFOBIZANT

= 1/7 m² // 1/21 LM

MORTAR / FUGENMÖRTEL

FUGA CEMENTOWA / SPÁROVACÍ HMOTA

NO JOINTS / NICHT VERFUGEN

BEZ FUGOWANIA / NESPÁRUJE SE



BROCKEN ROCK / 117 - ANCONA

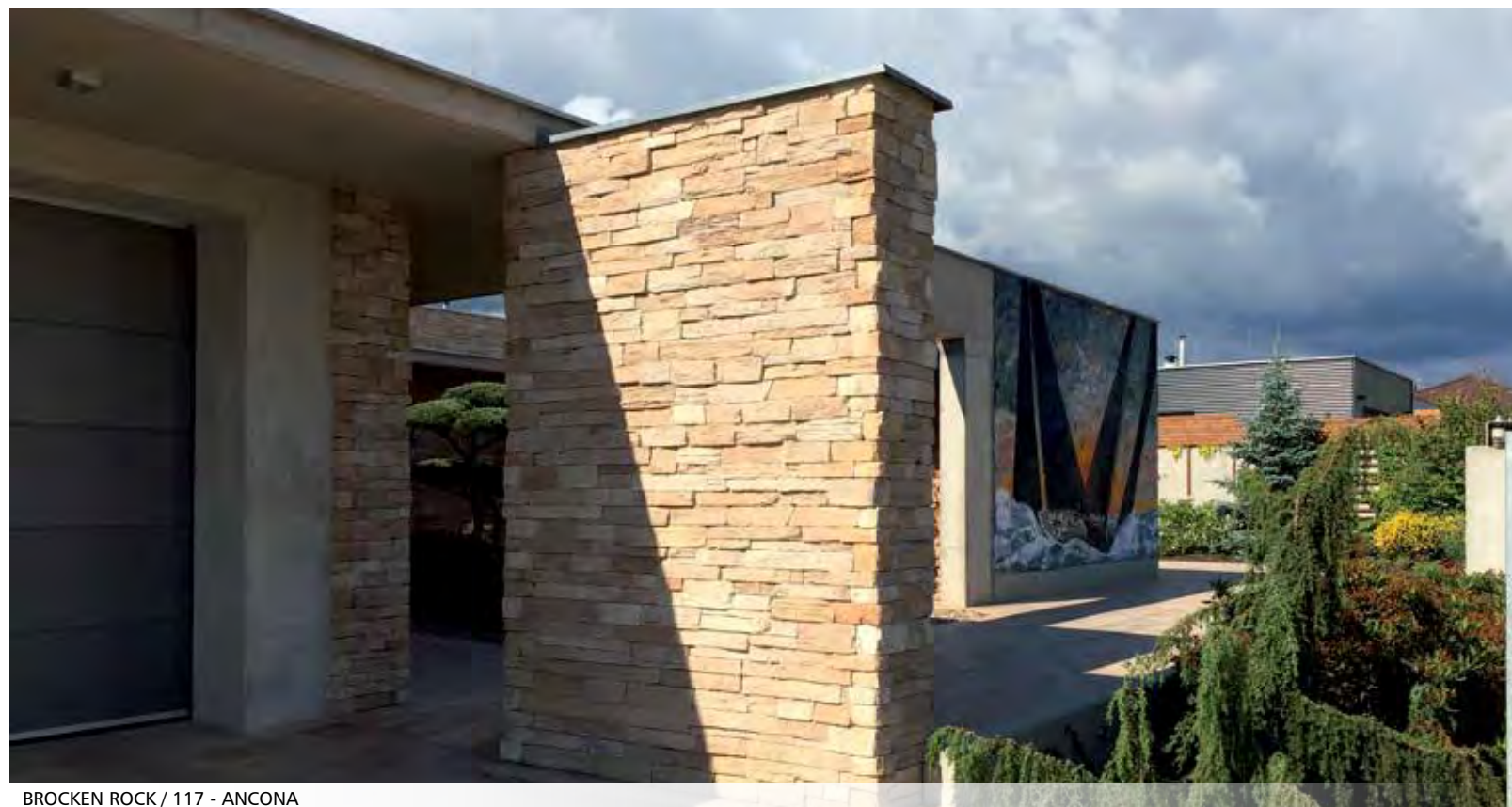

BROCKEN ROCK / 117 - ANCONA



MONTE NEGRO

MONTE NEGRO

PANELISED MODELS / PANELMODELLE / MODELE PANELOWE / FORMÁTOVANÝ OBKLAD

STONE VENEER / VERBLENDSTEIN / KAMIEŃ DEKORACYJNY / KAMENNÝ OBKLAD



408 - MONTE NEGRO



408 - MONTE NEGRO



408 - MONTE NEGRO



408 - MONTE NEGRO

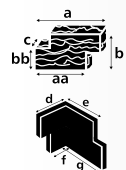

a = 530 mm / aa = 480 mm / b = 150 mm / bb = 75 mm
c = 10 - 45 mm

d = 205 mm / e = 145 mm / f = 170 mm / g = 185 mm
tolerance: 15 mm



= 14 pcs/St/szt/ks



= 6,66 pcs/St/szt/ks

1 LM

ADHESIVE / KLEBER / KLEJ / LEPIDLO

= 8 kg/m² // 3 kg/LM

HYDROFOBIZANT

= 1/7 m² // 1/21 LM

MORTAR / FUGENMÖRTEL
FUGA CEMENTOWA / SPÁROVACÍ HMOTA
NO JOINTS / NICHT VERFUGEN
BEZ FUGOWANIA / NESPÁRUJE SE



= 0,5 m² = 23 kg / 0,75 LM = 15 kg



= 30 x 0,5 m² = 15 m² = 700 kg
30 x 0,75 LM = 22,5 LM = 470 kg

CASTELO

CASTELO / CASTELO

PANELISED MODELS / PANELMODELLE / MODELE PANELOWE / FORMÁTOVANÝ OBKLAD

STONE VENEER / VERBLENDSTEIN / KAMIEŃ DEKORACYJNY / KAMENNÝ OBKLAD



208 - VALDEZ



213 - VIGO

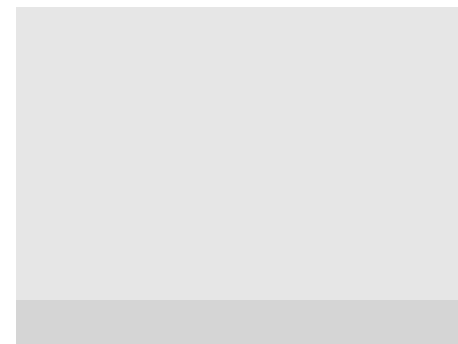

224 - PROVANCE



281 - ALICANTE



288 - TATRAN



224 - PROVANCE



208 - VALDEZ



281 - ALICANTE

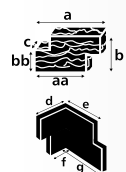

a = 500 mm / aa = 470 mm / b = 200 mm / bb = 100 mm
c = 15 - 40 mm

d = 120, 140, 155 mm / e = 240, 260, 275 mm / f = 95,
115, 135 mm / g = 265, 290, 300 mm

tolerance: 15 mm



= 10,5 pcs/St/szt/ks



= 5 pcs/St/szt/ks

1 LM



= 0,65 m² = 26 kg / 1 LM = 23 kg



= 30 x 0,65 m² = 19,5 m² = 820 kg
30 x 1 LM = 30 LM = 710 kg



PROFI BOX = 28,5 m²
1100x1110x1200 mm

ADHESIVE / KLEBER / KLEJ / LEPIDLO

= 8 kg/m² // 3 kg/LM

HYDROFOBIZANT

= 1/7 m² // 1/21 LM

MORTAR / FUGENMÖRTEL

FUGA CEMENTOWA / SPÁROVACÍ HMOTA

NO JOINTS / NICHT VERFUGEN

BEZ FUGOWANIA / NESPÁRUJE SE



***STONE VENEER
VERBLENDSTEIN
KAMIEŃ DEKORACYJNY
KAMENNÝ OBKLAD***

INDIVIDUAL MODELS / INDIVIDUELLE MODELE / MODELE INDYWIDUALNE / JEDNOTLIVÉ KAMENY

SPLIT SANDSTONE

GESPALTENER SANDSTEIN / ŠTÍPANÝ PÍSKOVEC

INDIVIDUAL MODELS / INDIVIDUELLE MODELLE / MODELE INDYWIDUALNE / JEDNOTLIVÉ KAMENY

STONE VENEER / VERBLENDSTEIN / KAMIEŃ DEKORACYJNY / KAMENNÝ OBKLAD



091 - ROMA

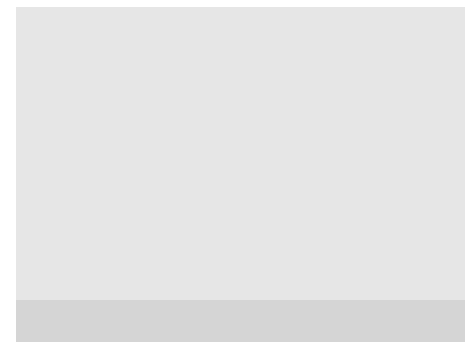
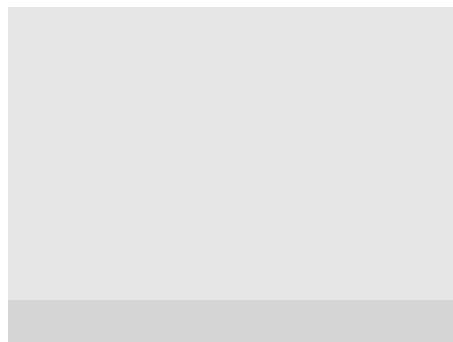

092 - CAPELA



094 - MIX



095 - COLIA



094 - MIX



091 - ROMA



092 - CAPELA



095 - COLIA



$a = 170 - 600 \text{ mm} / b = 40 - 180 \text{ mm} / c = 15 - 40 \text{ mm}$



$d = 150 - 550 \text{ mm} / e = 30 - 160 \text{ mm}$

tolerance: 15 mm



= cca 45 pcs/St/szt/ks

1 m²



= cca 10 pcs/St/szt/ks

1 LM



= 0,75 m² = 23 kg / 1,5 LM = 17 kg



= 30 x 0,75 m² = 22,5 m² = 690 kg
30 x 1,5 LM = 45 LM = 510 kg

ADHESIVE / KLEBER / KLEJ / LEPIDLO

= 8 kg/m² // 3 kg/LM

HYDROFOBIZANT

= 1/7 m² // 1/21 LM

**MORTAR / FUGENMÖRTEL
FUGA CEMENTOWA / SPÁROVACÍ HMOTA**

= 8 kg/m² // 3 kg/LM

RIVER STONE

FLUSSSTEIN / ŘÍČNÍ KÁMEN

INDIVIDUAL MODELS / INDIVIDUELLE MODELLE / MODELE INDYWIDUALNE / JEDNOTLIVÉ KAMENY

STONE VENEER / VERBLENDSTEIN / KAMIEN DEKORACYJNY / KAMENNÝ OBKLAD



033 - AMAZONIA



033 - AMAZONIA



033 - AMAZONIA



033 - AMAZONIA



033 - AMAZONIA



a = 200 - 400 mm / b = 90 - 180 mm / c = 30 - 70 mm

d = 170 - 350 mm / e = 80 - 150 mm

tolerance: 15 mm



= cca 35 pcs/St/szt/ks

1 m²



= cca 10 pcs/St/szt/ks

1 LM



= 1 m² = 30 kg / 2 LM = 20 kg



= 20 x 1 m² = 20 m² = 620 kg
20 x 2 LM = 40 LM = 420 kg



EUR = 15 m²

ADHESIVE / KLEBER / KLEJ / LEPIDLO

= 8 kg/m² // 3 kg/LM

HYDROFOBIZANT

= 1/7 m² // 1/21 LM

**MORTAR / FUGENMÖRTEL
FUGA CEMENTOWA / SPÁROVACÍ HMOTA**

= 8 kg/m² // 3 kg/LM



BROCKEN ROCK / 012 - ETNA

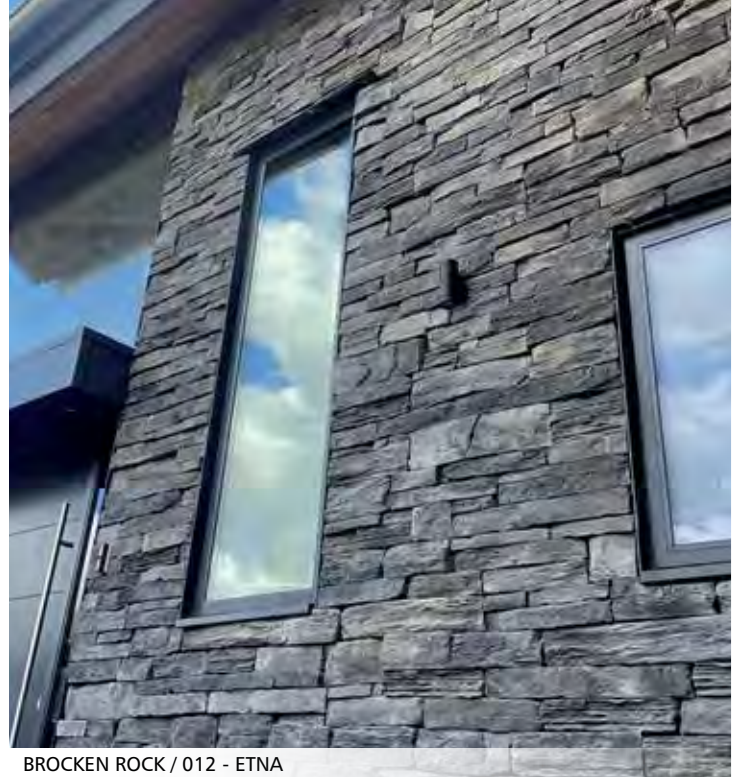

BROCKEN ROCK / 012 - ETNA

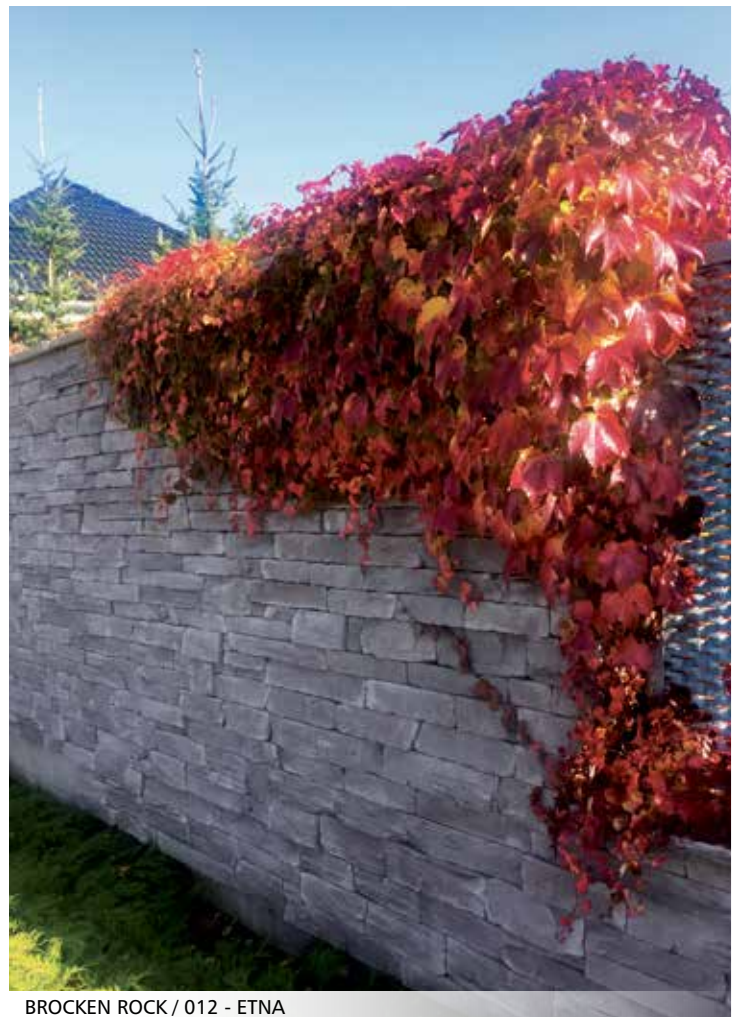

BROCKEN ROCK / 012 - ETNA



CASTLE WALL

BURGMAUER / HRADNÍ ZEĎ

INDIVIDUAL MODELS / INDIVIDUELLE MODELLE / MODELE INDYWIDUALNE / JEDNOTLIVÉ KAMENY

STONE VENEER / VERBLENDSTEIN / KAMIEŃ DEKORACYJNY / KAMENNÝ OBKLAD



024 - LANZAROTE

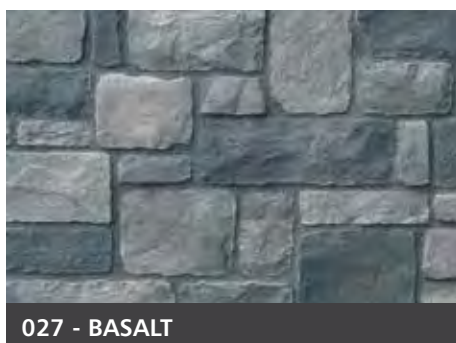
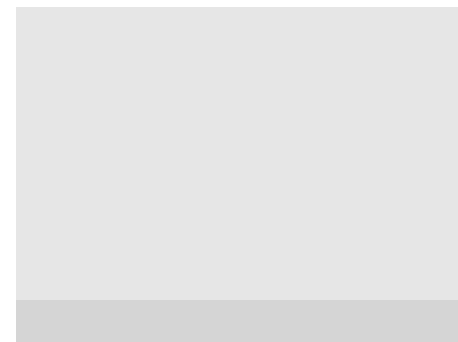
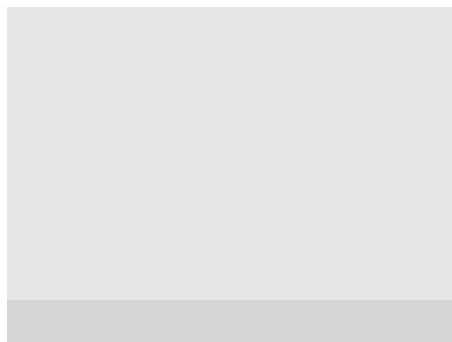

027 - BASALT



028 - CHAMPAGNE



225 - MANUELA



027 - BASALT



027 - BASALT



028 - CHAMPAGNE



024 - LANZAROTE



a = 160 - 350 mm / b = 60 - 350 mm / c = 10 - 30 mm



d = 140 - 350 mm / e = 50 - 140 mm

tolerance: 15 mm



= cca 35 pcs/St/szt/ks

1 m²



= cca 10 pcs/St/szt/ks

1 LM



= 1 m² = 33 kg / 2 LM = 26 kg



= 20 x 1 m² = 20 m² = 680 kg
20 x 2 LM = 40 LM = 540 kg



EUR = 12 m²

ADHESIVE / KLEBER / KLEJ / LEPIDLO

= 8 kg/m² // 3 kg/LM

HYDROFOBIZANT

= 1/7 m² // 1/21 LM

MORTAR / FUGENMÖRTEL

FUGA CEMENTOWA / SPÁROVACÍ HMOTA

= 8 kg/m² // 3 kg/LM

BROCKEN ROCK

LÁMANÁ SKÁLA

INDIVIDUAL MODELS / INDIVIDUELLE MODELLE / MODELE INDYWIDUALNE / JEDNOTLIVÉ KAMENY

STONE VENEER / VERBLENDSTEIN / KAMIEŃ DEKORACYJNY / KAMENNÝ OBKLAD



011 - ALEXANDRIA



012 - ETNA



013 - CHAMPAGNE

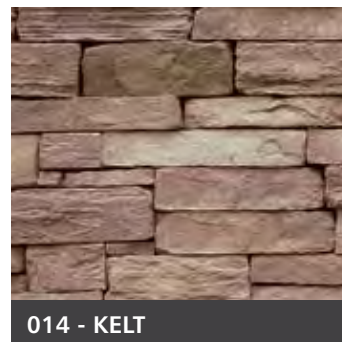

014 - KELT



015 - TRIVENTO



116 - OXID



018 - VENTURA



117 - ANCONA



019 - NORDICA



019 - NORDICA



117 - ANCONA + 014 - KELT



015 - „special“



012 - ETNA



a = 170 - 600 mm / b = 40 - 180 mm / c = 20 - 50 mm

d = 160 - 550 mm / e = 100 - 400 mm

tolerance: 15 mm



1 m²

= cca 35 pcs/St/szt/ks



1 LM

= cca 10 pcs/St/szt/ks



= 0,5 m² = 25 kg / 1 LM = 13 kg



= 30 x 0,5 m² = 15 m² = 750 kg
30 x 1 LM = 30 LM = 390 kg



EUR = 12 m²

ADHESIVE / KLEBER / KLEJ / LEPIDLO

= 8 kg/m² // 3 kg/LM

HYDROFOBIZANT

= 1/7 m² // 1/21 LM

MORTAR / FUGENMÖRTEL

FUGA CEMENTOWA / SPÁROVACÍ HMOTA

= 10 kg/m² // 3 kg/LM





LIMESTONE

LIMESTONE / OPUKA

INDIVIDUAL MODELS / INDIVIDUELLE MODELLE / MODELE INDYWIDUALNE / JEDNOTLIVÉ KAMENY

STONE VENEER / VERBLENDSTEIN / KAMIEN DEKORACYJNY / KAMENNÝ OBKLAD



060 - OPUKA / LIMESTONE



063 - OPUKA / LIMESTONE CHAMPAGNE



063 - LIMESTONE CHAMPAGNE



060 - LIMESTONE



060 - LIMESTONE



060 - LIMESTONE



a = 150 - 500 mm / b = 100 - 270 mm / c = 20 - 60 mm

d = 100 - 450 mm / e = 90 - 300 mm

tolerance: 15 mm



1 m²

= cca 21 pcs/St/szt/ks



1 LM

= cca 10 pcs/St/szt/ks



= 0,5 m² = 17 kg / 1 LM = 18 kg



= 30 x 0,5 m² = 15 m² = 510 kg
30 x 1 LM = 30 LM = 540 kg



EUR = 10 m²

ADHESIVE / KLEBER / KLEJ / LEPIDLO

= 8 kg/m² // 3 kg/LM

HYDROFOBIZANT

= 1/7 m² // 1/21 LM

**MORTAR / FUGENMÖRTEL
FUGA CEMENTOWA / SPÁROVACÍ HMOTA**

= 8 kg/m² // 3 kg/LM

MIX ALPINA

INDIVIDUAL MODELS / INDIVIDUELLE MODELLE / MODELE INDYWIDUALNE / JEDNOTLIVÉ KAMENY

STONE VENEER / VERBLENDSTEIN / KAMIEŃ DEKORACYJNY / KAMENNÝ OBKLAD



770 - ALPINA



$a = 70 - 600 \text{ mm} / b = 10 - 300 \text{ mm} / c = 10 - 60 \text{ mm}$

$d = 250 - 550 \text{ mm} / e = 100 - 250 \text{ mm}$

tolerance: 15 mm



= cca 21 pcs/St/szt/ks

1 m²



= cca 10 pcs/St/szt/ks

1 LM



= 0,75 m² = 25 kg / 1 LM = 15 kg



= 30 x 0,75 m² = 22,5 m² = 750 kg
30 x 1 LM = 30 LM = 450 kg



EUR = 15 m²

ADHESIVE / KLEBER / KLEJ / LEPIDLO

= 8 kg/m² // 3 kg/LM

HYDROFOBIZANT

= 1/7 m² // 1/21 LM

MORTAR / FUGENMÖRTEL

FUGA CEMENTOWA / SPÁROVACÍ HMOTA

= 8 kg/m² // 3 kg/LM



MIX DAVOS



MIX COLORADO

INDIVIDUAL MODELS / INDIVIDUELLE MODELLE / MODELE INDYWIDUALNE / JEDNOTLIVÉ KAMENY

STONE VENEER / VERBLENDSTEIN / KAMIEŃ DEKORACYJNY / KAMENNÝ OBKLAD



025 - COLORADO



a = 150 - 500 mm / b = 100 - 300 mm / c = 20 - 60 mm
d = 140 - 450 mm / e = 80 - 150 mm



tolerance: 15 mm



= cca 21 pcs/St/szt/ks
1 m²



= cca 10 pcs/St/szt/ks
1 LM



= 0,75 m² = 27 kg / 1 LM = 15 kg



= 30 x 0,75 m² = 22,5 m² = 810 kg
30 x 1 LM = 30 LM = 450 kg



EUR = 12 m²

ADHESIVE / KLEBER / KLEJ / LEPIDLO

= 8 kg/m² // 3 kg/LM

HYDROFOBIZANT

= 1/7 m² // 1/21 LM

MORTAR / FUGENMÖRTEL FUGA CEMENTOWA / SPÁROVACÍ HMOTA

= 8 kg/m² // 3 kg/LM

MIX RUSTICO

INDIVIDUAL MODELS / INDIVIDUELLE MODELLE / MODELE INDYWIDUALNE / JEDNOTLIVÉ KAMENY

STONE VENEER / VERBLENDSTEIN / KAMIEN DEKORACYJNY / KAMENNÝ OBKLAD



661 - RUSTICO



$a = 150 - 500 \text{ mm} / b = 100 - 300 \text{ mm} / c = 20 - 60 \text{ mm}$
 $d = 140 - 450 \text{ mm} / e = 80 - 150 \text{ mm}$



tolerance: 15 mm



= cca 21 pcs/St/szt/ks

1 m²



= cca 10 pcs/St/szt/ks

1 LM



= 0,75 m² = 25 kg / 1,5 LM = 18 kg



= 30 x 0,75 m² = 22,5 m² = 750 kg
 30 x 1,5 LM = 45 LM = 540 kg

ADHESIVE / KLEBER / KLEJ / LEPIDLO

= 8 kg/m² // 3 kg/LM

HYDROFOBIZANT

= 1/7 m² // 1/21 LM

**MORTAR / FUGENMÖRTEL
 FUGA CEMENTOWA / SPÁROVACÍ HMOTA**

= 8 kg/m² // 3 kg/LM

MIX GRIGIO

INDIVIDUAL MODELS / INDIVIDUELLE MODELLE / MODELE INDYWIDUALNE / JEDNOTLIVÉ KAMENY

STONE VENEER / VERBLENDSTEIN / KAMIEN DEKORACYJNY / KAMENNÝ OBKLAD



772 - GRIGIO



a = 150 - 500 mm / b = 100 - 300 mm / c = 20 - 60 mm
d = 140 - 450 mm / e = 80 - 150 mm



tolerance: 15 mm



= cca 21 pcs/St/szt/ks

1 m²



= cca 10 pcs/St/szt/ks

1 LM



= 1 m² = 35 kg / 2 LM = 28 kg



= 20 x 1 m² = 20 m² = 720 kg
20 x 2 LM = 40 LM = 580 kg



EUR = 15 m²

ADHESIVE / KLEBER / KLEJ / LEPIDLO

= 8 kg/m² // 3 kg/LM

HYDROFOBIZANT

= 1/7 m² // 1/21 LM

MORTAR / FUGENMÖRTEL FUGA CEMENTOWA / SPÁROVACÍ HMOTA

= 8 kg/m² // 3 kg/LM



MIX TOSCANA



MIX TOSCANA

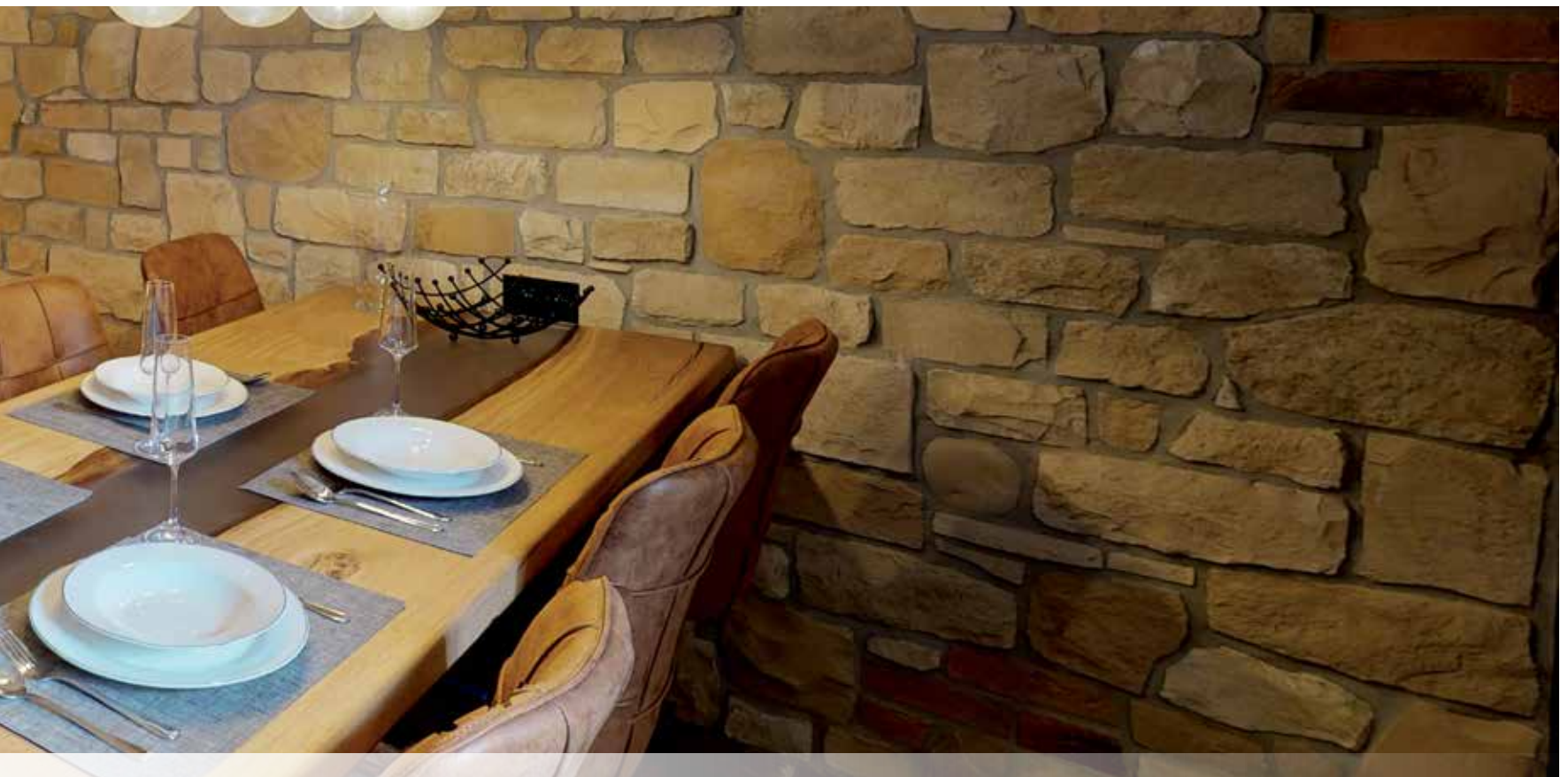
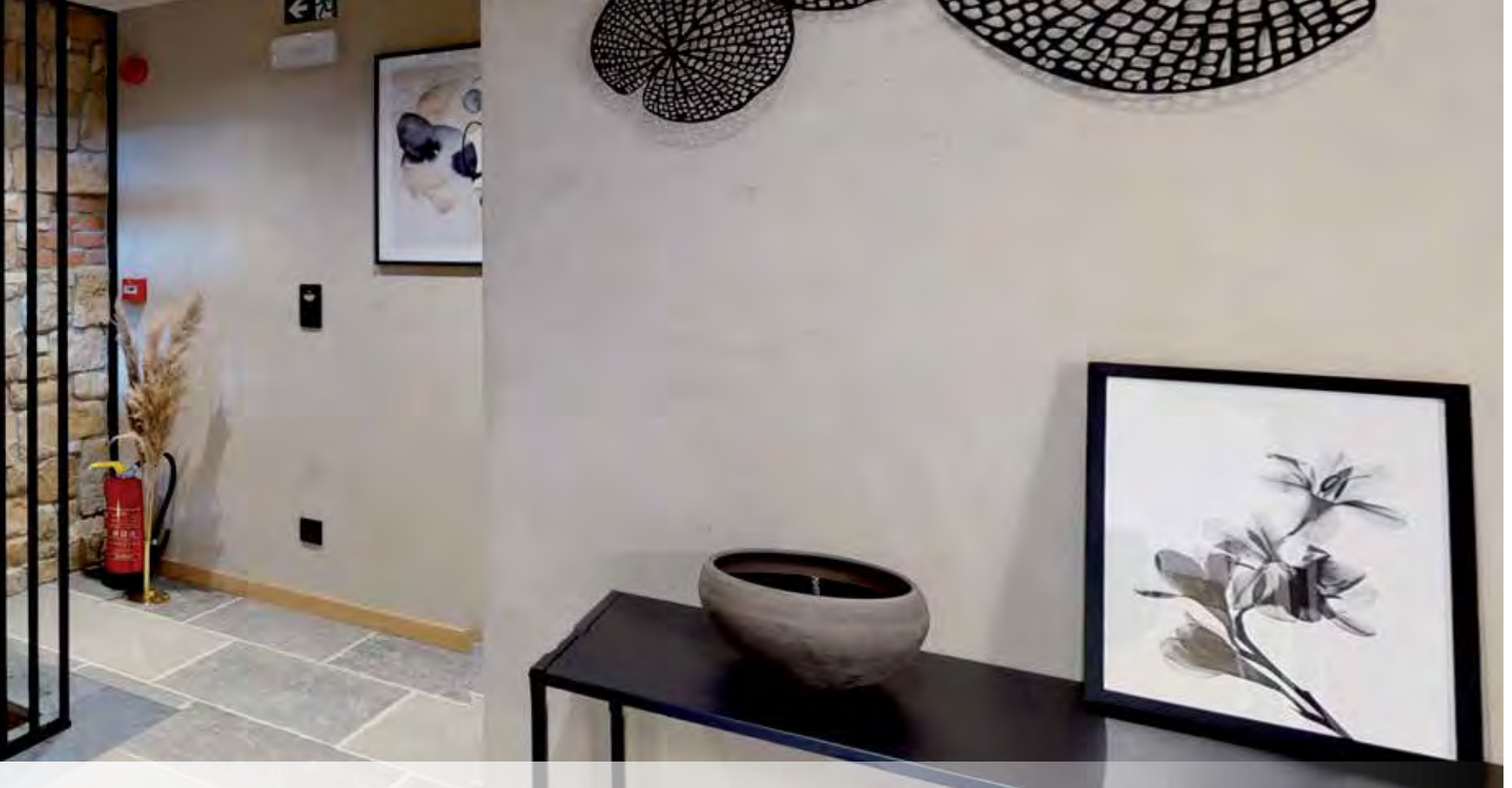

MIX TOSCANA

INDIVIDUAL MODELS / INDIVIDUELLE MODELLE / MODELE INDYWIDUALNE / JEDNOTLIVÉ KAMENY

STONE VENEER / VERBLENDSTEIN / KAMIEŃ DEKORACYJNY / KAMENNÝ OBKLAD



774 - TOSCANA



a = 150 - 500 mm / b = 100 - 300 mm / c = 20 - 60 mm



d = 140 - 450 mm / e = 80 - 150 mm

tolerance: 15 mm



= cca 21 pcs/St/szt/ks

1 m²



= cca 10 pcs/St/szt/ks

1 LM



= 1 m² = 35 kg / 2 LM = 28 kg



= 20 x 1 m² = 20 m² = 720 kg
20 x 2 LM = 40 LM = 580 kg



EUR = 15 m²

ADHESIVE / KLEBER / KLEJ / LEPIDLO

= 8 kg/m² // 3 kg/LM

HYDROFOBIZANT

= 1/7 m² // 1/21 LM

MORTAR / FUGENMÖRTEL

FUGA CEMENTOWA / SPÁROVACÍ HMOTA

= 8 kg/m² // 3 kg/LM

MIX COUNTRY

INDIVIDUAL MODELS / INDIVIDUELLE MODELLE / MODELE INDYWIDUALNE / JEDNOTLIVÉ KAMENY

STONE VENEER / VERBLENDSTEIN / KAMIEN DEKORACYJNY / KAMENNÝ OBKLAD



775 - COUNTRY



$a = 70 - 600 \text{ mm} / b = 20 - 300 \text{ mm} / c = 10 - 60 \text{ mm}$
 $d = 100 - 500 \text{ mm} / e = 80 - 250 \text{ mm}$



tolerance: 15 mm



$1 \text{ m}^2 = \text{cca } 21 \text{ pcs/St/szt/ks}$



$1 \text{ LM} = \text{cca } 10 \text{ pcs/St/szt/ks}$



$= 1 \text{ m}^2 = 35 \text{ kg} / 2 \text{ LM} = 28 \text{ kg}$



$= 20 \times 1 \text{ m}^2 = 20 \text{ m}^2 = 720 \text{ kg}$
 $20 \times 2 \text{ LM} = 40 \text{ LM} = 580 \text{ kg}$



$\text{EUR} = 15 \text{ m}^2$

ADHESIVE / KLEBER / KLEJ / LEPIDLO

$= 8 \text{ kg/m}^2 // 3 \text{ kg/LM}$

HYDROFOBIZANT

$= 1/7 \text{ m}^2 // 1/21 \text{ LM}$

MORTAR / FUGENMÖRTEL FUGA CEMENTOWA / SPÁROVACÍ HMOTA

$= 8 \text{ kg/m}^2 // 3 \text{ kg/LM}$

MIX TIROL

INDIVIDUAL MODELS / INDIVIDUELLE MODELLE / MODELE INDYWIDUALNE / JEDNOTLIVÉ KAMENY

STONE VENEER / VERBLENDSTEIN / KAMIEN DEKORACYJNY / KAMENNÝ OBKLAD



776 - TIROL



a = 170 - 600 mm / b = 40 - 300 mm / c = 20 - 50 mm



d = 150 - 550 mm / e = 80 - 250 mm

tolerance: 15 mm



1 m²

= cca 21 pcs/St/szt/ks



1 LM

= cca 10 pcs/St/szt/ks



= 0,5 m² = 20 kg / 1 LM = 12 kg



= 30 x 0,5 m² = 15 m² = 750 kg
30 x 1 LM = 30 LM = 390 kg



EUR = 12 m²

ADHESIVE / KLEBER / KLEJ / LEPIDLO

= 8 kg/m² // 3 kg/LM

HYDROFOBIZANT

= 1/7 m² // 1/21 LM

MORTAR / FUGENMÖRTEL FUGA CEMENTOWA / SPÁROVACÍ HMOTA

= 12 kg/m² // 3 kg/LM





MIX DAVOS

INDIVIDUAL MODELS / INDIVIDUELLE MODELLE / MODELE INDYWIDUALNE / JEDNOTLIVÉ KAMENY

STONE VENEER / VERBLENDSTEIN / KAMIEN DEKORACYJNY / KAMENNÝ OBKLAD



781 - DAVOS



$a = 70 - 600 \text{ mm} / b = 20 - 300 \text{ mm} / c = 10 - 60 \text{ mm}$

$d = 100 - 500 \text{ mm} / e = 80 - 250 \text{ mm}$

tolerance: 15 mm



= cca 21 pcs/St/szt/ks

1 m²



= cca 10 pcs/St/szt/ks

1 LM

ADHESIVE / KLEBER / KLEJ / LEPIDLO

= 8 kg/m² // 3 kg/LM

HYDROFOBIZANT

= 1/7 m² // 1/21 LM

MORTAR / FUGENMÖRTEL

FUGA CEMENTOWA / SPÁROVACÍ HMOTA

= 8 kg/m² // 3 kg/LM



= 1 m² = 35 kg / 2 LM = 28 kg



= 20 x 1 m² = 20 m² = 720 kg
20 x 2 LM = 40 LM = 580 kg



EUR = 15 m²

MIX CARRARA

INDIVIDUAL MODELS / INDIVIDUELLE MODELLE / MODELE INDYWIDUALNE / JEDNOTLIVÉ KAMENY

STONE VENEER / VERBLENDSTEIN / KAMIEN DEKORACYJNY / KAMENNÝ OBKLAD



771 - CARRARA



a = 70 - 600 mm / b = 20 - 300 mm / c = 10 - 60 mm

d = 100 - 500 mm / e = 80 - 250 mm

tolerance: 15 mm



1 m²

= cca 21 pcs/St/szt/ks



1 LM

= cca 10 pcs/St/szt/ks



= 1 m² = 35 kg / 2 LM = 28 kg



= 20 x 1 m² = 20 m² = 720 kg
20 x 2 LM = 40 LM = 580 kg



EUR = 15 m²

ADHESIVE / KLEBER / KLEJ / LEPIDLO

= 8 kg/m² // 3 kg/LM

HYDROFOBIZANT

= 1/7 m² // 1/21 LM

MORTAR / FUGENMÖRTEL

FUGA CEMENTOWA / SPÁROVACÍ HMOTA

= 8 kg/m² // 3 kg/LM





***PORTLAND PAVEMENT
PORTLANDPFLASTER
BRUK PORTLADZKI
PORTLANDSKÁ DLAŽBA***

RUSTIC / TAORMINA

BRICK PAVING / ZIEGELPFLASTER / CIHLOVÁ DLAŽBA

PORTLAND PAVEMENT / PORTLANDPFLASTER / BRUK PORTLADZKI / PORTLANDSKÁ DLAŽBA



050 - RUSTIC



051- TAORMINA



050 - RUSTIC



050 - RUSTIC



051 - TAORMINA



051 - TAORMINA



a = 190 mm / b = 90 mm / c = 28 mm

tolerance: 8 mm



1 m² = 52 pcs/St/szt/ks

= 46 kg



= 0,5 m² = 23 kg



= 40 x 0,5 m² = 20 m² = 960 kg



EUR = 15 m²
= 768 pcs/St/szt/ks
= 710 kg

ADHESIVE / KLEBER / KLEJ / LEPIDLO

= 12 kg/m²

MORTAR / FUGENMÖRTEL
FUGA CEMENTOWA / SPÁROVACÍ HMOTA

= 10 kg/m²

WAXCOATING / WACHSANSTRICH
POWŁOKA WOSKOWA / NÁTĚŘ

= 0,1 l/m²

SEVILLA

BRICK PAVING / ZIEGELPFLASTER / CIHLOVÁ DLAŽBA

PORTLAND PAVEMENT / PORTLANDPFLASTER / BRUK PORTLADZKI / PORTLANDSKÁ DLAŽBA

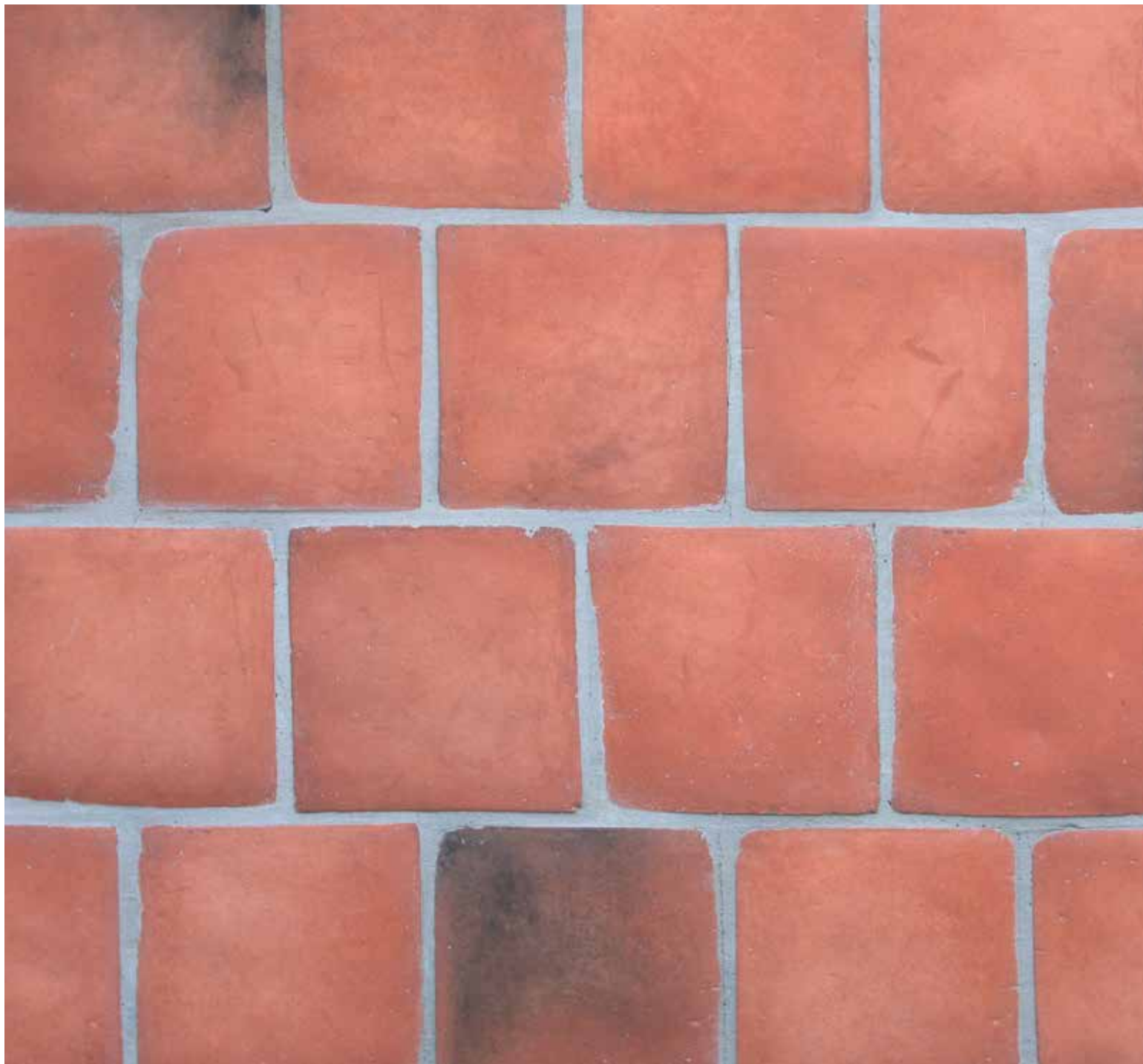

054 - SEVILLA



a = 205 mm / b = 205 mm / c = 25 mm

tolerance: 8 mm



= 23 pcs/St/szt/ks

= 52 kg

ADHESIVE / KLEBER / KLEJ / LEPIDLO

= 12 kg/m²

**MORTAR / FUGENMÖRTEL
FUGA CEMENTOWA / SPÁROVACÍ HMOTA**

= 10 kg/m²

**WAXCOATING / WACHSANSTRICH
POWŁOKA WOSKOWA / NÁTĚŘ**

= 0,1 l/m²



= 0,5 m² = 23 kg



= 35 x 0,5 m² = 17,5 m² = 805 kg



EUR = 10 m²
= 230 pcs/St/szt/ks
= 560 kg

SEVILLA NEW

BRICK PAVING / ZIEGELPFLASTER / CIHLOVÁ DLAŽBA

PORTLAND PAVEMENT / PORTLANDPFLASTER / BRUK PORTLADZKI / PORTLANDSKÁ DLAŽBA



055 - SEVILLA NEW



a = 175 mm / b = 175 mm / c = 30 mm

tolerance: 8 mm



= cca 30 pcs/St/szt/ks
1 m² = 65 kg

ADHESIVE / KLEBER / KLEJ / LEPIDLO

= 12 kg/m²

**MORTAR / FUGENMÖRTEL
FUGA CEMENTOWA / SPÁROVACÍ HMOTA**

= 10 kg/m²

**WAXCOATING / WACHSANSTRICH
POWŁOKA WOSKOWA / NÁTĚŘ**

= 0,1 l/m²



= 0,5 m² = **33 kg**



= 35 x 0,5 m² = **17,5 m² = 1155 kg**



EUR = 10 m²
= 300 pcs/St/szt/ks
= 670 kg



BROCKEN ROCK / 012 - ETNA + PORTLAND PAVEMENT (Mix)



PORTLAND PAVEMENT (Mix)



PORTLAND PAVEMENT / 054 - SEVILLA + 050 - RUSTIC



PORTLAND PAVEMENT (Mix)



PORTLAND PAVEMENT (Mix)

BRICK

BRICK PAVING / ZIEGELPFLASTER / CIHLOVÁ DLAŽBA

PORTLAND PAVEMENT / PORTLANDPFLASTER / BRUK PORTLADZKI / PORTLANDSKÁ DLAŽBA



059 - BRICK



056 - BRICK GARDA



057 - BRICK PICCOLI



056 - BRICK GARDA



059 - BRICK



059 - BRICK



056 - BRICK GARDA



$a = 280 \text{ mm} / b = 135 \text{ mm} / c = 28 \text{ mm}$



$a = 135 \text{ mm} / b = 135 \text{ mm} / c = 28 \text{ mm}$

tolerance: 8 mm



= 27 pcs/St/szt/ks



= 54 pcs/St/szt/ks



= 24 + 6 pcs/St/szt/ks

1 m²

= 52 kg



= 0,5 m² = 26 kg



= 30 x 0,5 m² = 15 m² = 780 kg



EUR = 10 m² = 540 kg

ADHESIVE / KLEBER / KLEJ / LEPIDLO

= 12 kg/m²

MORTAR / FUGENMÖRTEL
FUGA CEMENTOWA / SPÁROVACÍ HMOTA

= 10 kg/m²

WAXCOATING / WACHSANSTRICH
POWŁOKA WOSKOWA / NÁTĚŘ

= 0,1 l/m²

MONTANA

BRICK / PFLASTER / DLAŽBA

PORTLAND PAVEMENT / PORTLANDPFLASTER / BRUK PORTLADZKI / PORTLANDSKÁ DLAŽBA



058 - MONTANA



053 - MONTANA COLOSEUM

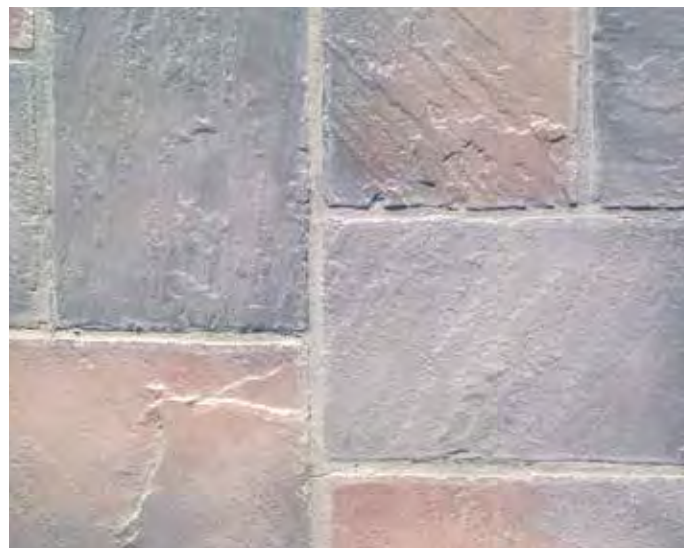

0576 - MONTANA TIROL



053 - MONTANA COLOSEUM



058 - MONTANA

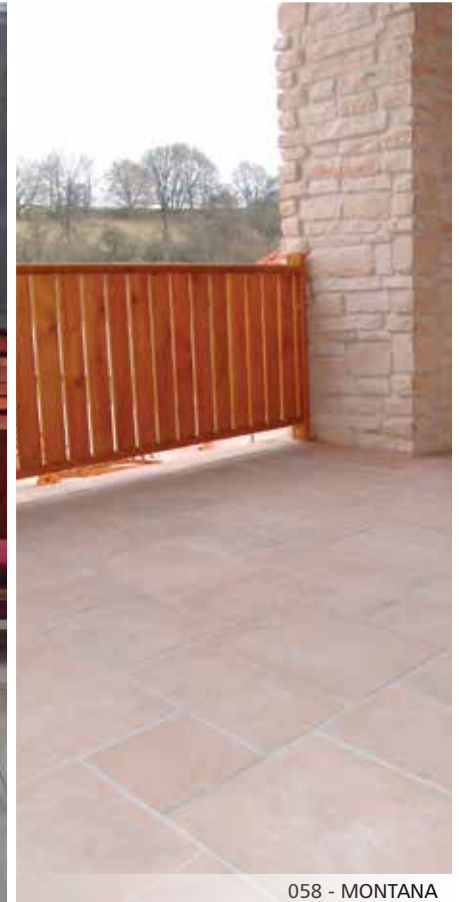

058 - MONTANA

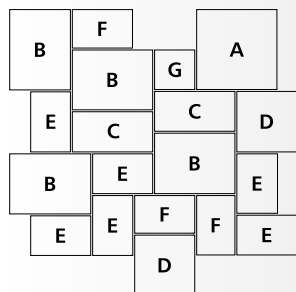

1 segment = 2 m² = 112 kg

A = 450 x 450 mm / 1x E = 338 x 225 mm / 6x
 B = 450 x 338 mm / 4x F = 338 x 215 mm / 3x
 C = 450 x 225 mm / 2x G = 225 x 225 mm / 1x
 D = 338 x 338 mm / 2x

thickness / Stärke / grubość / tloušťka = cca 28 mm



EUR = 12 m² = 114 pcs/St/szt/ks = 690 kg

ADHESIVE / KLEBER / KLEJ / LEPIDLO

= 15 kg/m²

**MORTAR / FUGENMÖRTEL
 FUGA CEMENTOWA / SPÁROVACÍ HMOTA**

= 10 kg/m²

**WAXCOATING / WACHSANSTRICH
 POWŁOKA WOSKOWA / NÁTĚR**

= 0,1 l/m²



***BRICK VENEER
KLINKERRIEMCHEN
CEGŁA DEKORACYJNA
CIHLOVÉ PÁSKY***

HOLLAND BRICK

BRICK VENEER / KLINKERRIEMCHEN / CEGŁA DEKORACYJNA / CIHLOVÉ PÁSKY

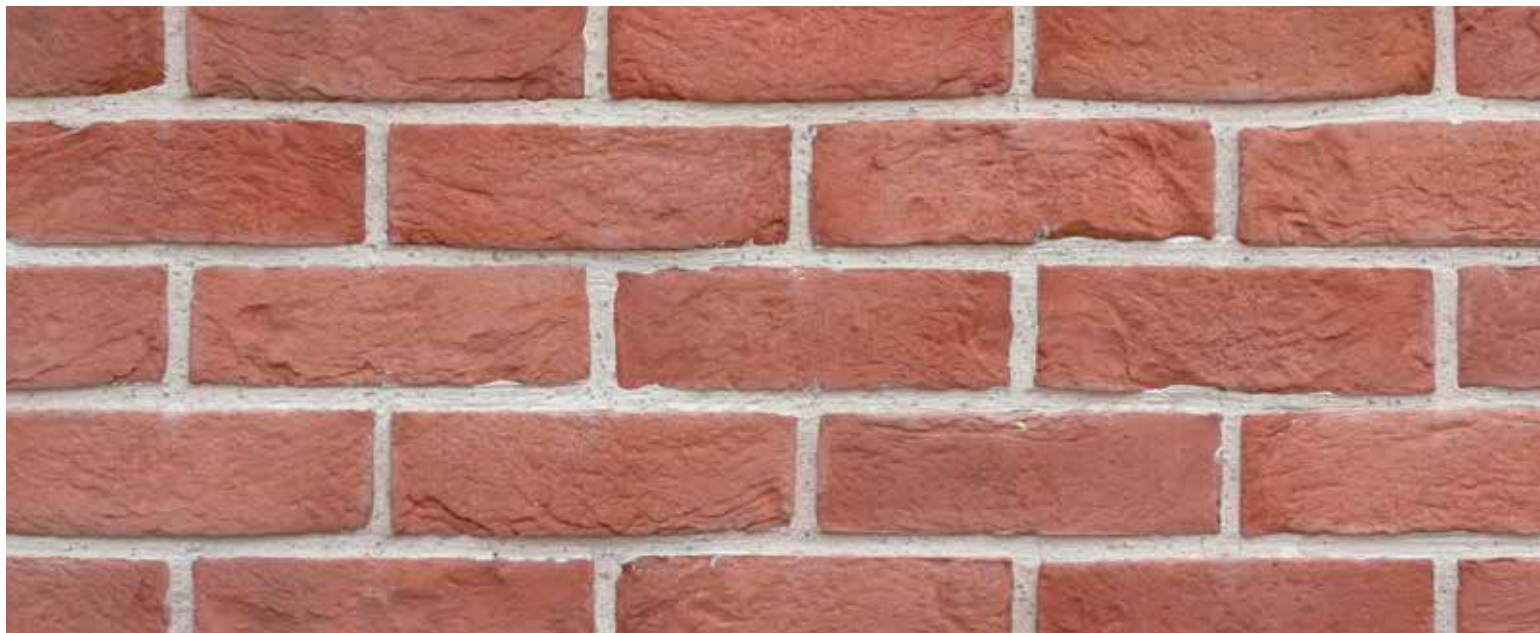



306 - BRUGGY



303 - GRANADA



305 - NEVADA



302 - BASTIA



$a = 210 \text{ mm} / b = 65 \text{ mm} / c = 10 - 15 \text{ mm}$

$d = 185 \text{ mm} / e = 70 \text{ mm}$

tolerance: 15 mm



= 56 pcs/St/szt/ks

1 m²



= 14 pcs/St/szt/ks

1 LM



= 1 m² = 23 kg / 1 LM = 10 kg



= 35 x 1 m² = 35 m² = 820 kg
35 x 1 LM = 35 LM = 370 kg



EUR = 15 m²

ADHESIVE / KLEBER / KLEJ / LEPIDLO

= 6 kg/m² // 3 kg/LM

HYDROFOBIZANT

= 1/7 m² // 1/21 LM

MORTAR / FUGENMÖRTEL

FUGA CEMENTOWA / SPÁROVACÍ HMOTA

= 8 kg/m² // 3 kg/LM

CASTLE BRICK

BRICK VENEER / KLINKERRIEMCHEN / CEGŁA DEKORACYJNA / CIHLOVÉ PÁSKY

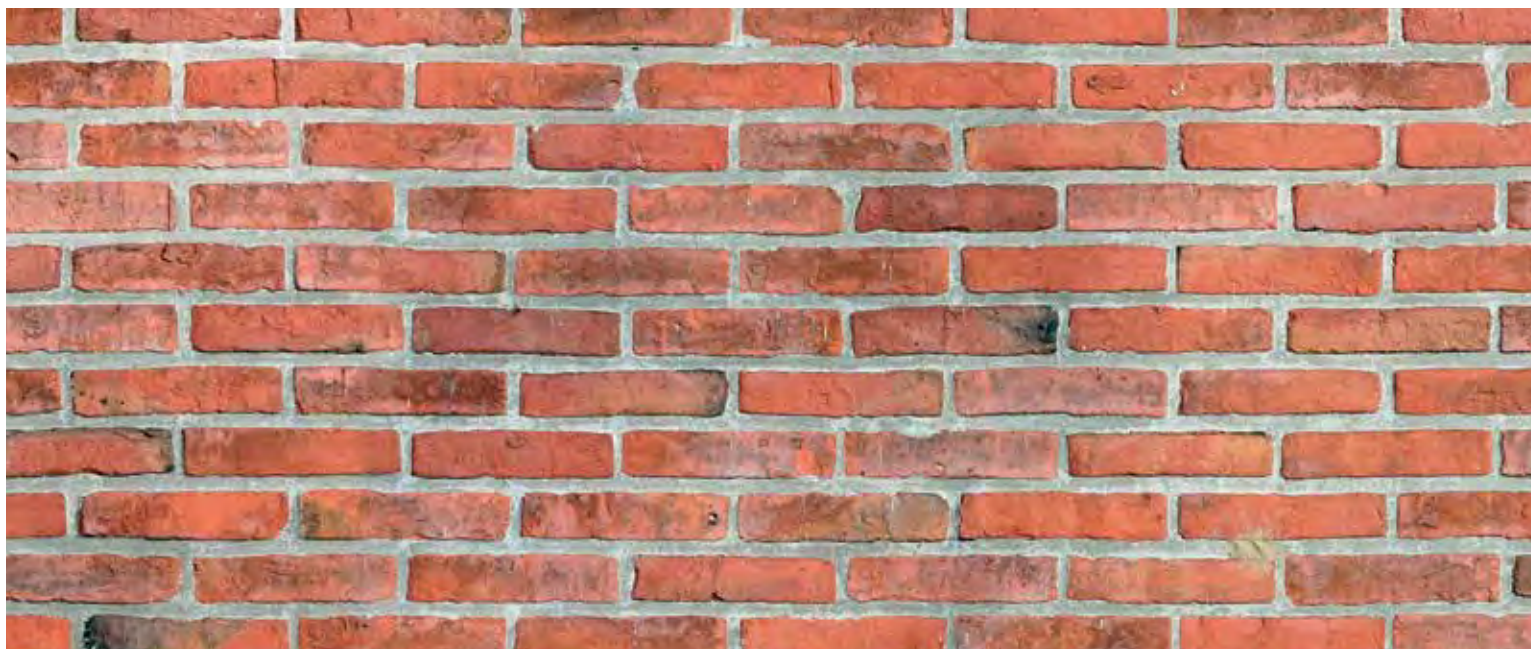

313 - PAVLOV

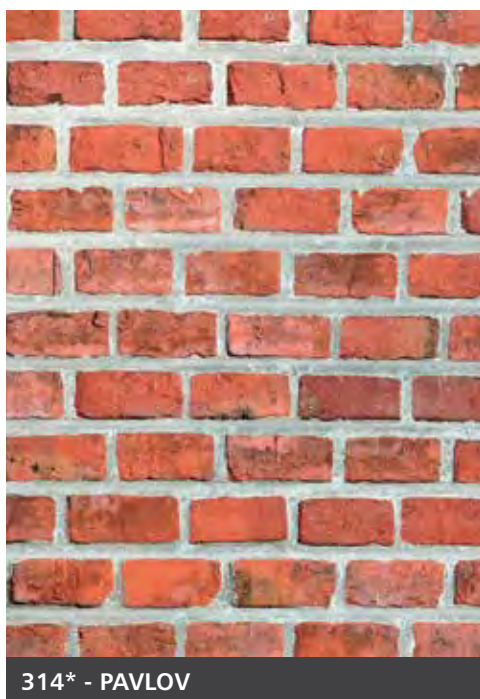

314* - PAVLOV



315 - CREMONA



316* - CREMONA



313 + 314* - PAVLOV

313 + 314* PAVLOV



313 - PAVLOV



$a = 280 - 305 \text{ mm} (160 - 165\text{mm}^*) / b = 65 \text{ mm}$

$c = 20 - 25 \text{ mm} / d = 280 \text{ mm} / e = 140 \text{ mm}$

tolerance: 15 mm



$= 44 (77^*) \text{ pcs/St/szt/ks}$

1 m²



$= 14 \text{ pcs/St/szt/ks}$

1 LM



$= 1 \text{ m}^2 = 34 \text{ kg} / 1 \text{ LM} = 21 \text{ kg}$



$= 30 \times 1 \text{ m}^2 = 30 \text{ m}^2 = 1020 \text{ kg}$

$30 \times 1 \text{ LM} = 30 \text{ LM} = 630 \text{ kg}$



EUR = 15 m²

ADHESIVE / KLEBER / KLEJ / LEPIDLO

= 6 kg/m² // 3 kg/LM

HYDROFOBIZANT

= 1/7 m² // 1/21 LM

MORTAR / FUGENMÖRTEL

FUGA CEMENTOWA / SPÁROVACÍ HMOTA

= 8 kg/m² // 3 kg/LM

MURA BRICK

BRICK VENEER / KLINKERRIEMCHEN / CEGŁA DEKORACYJNA / CIHLOVÉ PÁSKY



328 - FUEGO

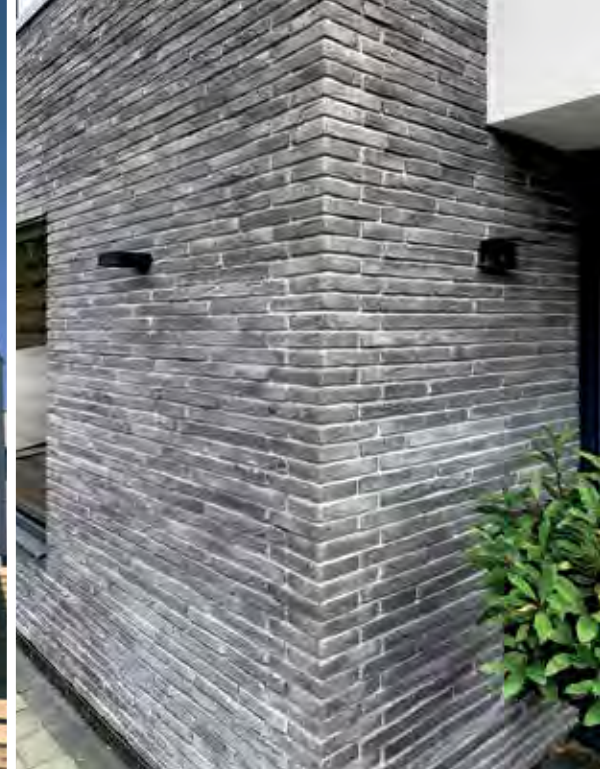

a = 500 mm / b = 40 mm

c = 40 mm / d = 220 mm / e = 130 mm

tolerance: 15 mm



1 m²

incl. joint / inkl. Fuge / s fugou / vč. spáry
= 40 pcs/St/szt/ks
without joint / ohne Fuge / bez fugi / beze spáry
= 50 pcs/St/ks



1 LM

incl. joint / inkl. Fuge / s fugou / vč. spáry
= 21 pcs/St/szt/ks
without joint / ohne Fuge / bez fugi / beze spáry
= 25 pcs/St/szt/ks



■ = 20 ks = 22 kg

◩ = 25 ks = 27 kg



■ = 20 x 20 pcs/St/szt/ks = 400 pcs/St/szt/ks = 440 kg

◩ = 40 x 25 pcs/St/szt/ks = 1000 pcs/St/szt/ks = 1080kg



PROFI BOX
= 1500 pcs/St/szt/ks
1100x1110x1200 mm

ADHESIVE / KLEBER / KLEJ / LEPIDLO

= 6 kg/m² // 3 kg/LM

HYDROFOBIZANT

= 1/7 m² // 1/21 LM

MORTAR / FUGENMÖRTEL FUGA CEMENTOWA / SPÁROVACÍ HMOTA

= 8 kg/m² // 3 kg/LM





WINDOW TRIM / FENSTERRAHMUNG / WYKONCZENIE OKIEN / ŠPALETY

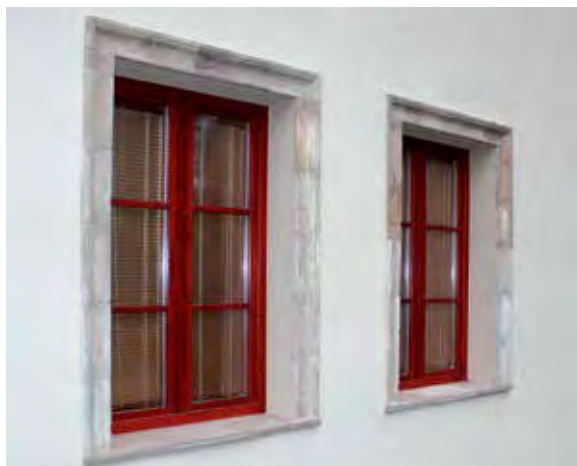

a = 270 mm / b = 120 mm / c = cca 60 mm
tolerance: 15 mm

2 kg



PARAPETS / FENSTERBANK / PARAPETY / PARAPETY



a = 330 mm / b = 90 mm / c = cca 90 mm
tolerance: 15 mm

cca 3 kg

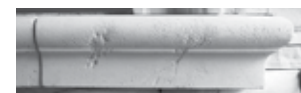

COPING STONE / ABDECKPLATTE / PŁYTY KRYJĄCE / KRYCÍ DESKY



KLASIK



MONTANA



a = 450 mm / b = 345, 390, 490 mm / c = 40 - 50 mm
tolerance: 15 mm

18, 20, 22 kg

a = 450 mm / b = 350, 450 mm / c = cca 25 mm
tolerance: 15 mm



8,9 kg

SUN-DIAL / SONNENUHR / ZEGAR SŁONECZNY / SLUNEČNÍ HODINY



a = 550 mm // thickness / stärke / grubość / tloušťka = 40 - 50 mm
tolerance: 15 mm

17 kg



WILD STONE LM - ADHESIVE / KLEBER / KLEJ / LEPIDLO

PACKAGING / VERPAKUNG / OPAKOWANIE / BALENÍ
- 25 kg

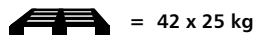

CONSUMPTION / VERBRAUCH / ZUŻYCIE / SPOTŘEBA
- 5-8 kg/m²

CLASS / KLASSE / KLASA / TRÍDA
- C2TE S1

COLOR / FARBTÖNE / ODCIENIE / ODSTÍNY

**WILD STONE SH - GROUT / FUGELMÖRTEL / FUGA CEMENTOWA / SPÁROVACÍ HMOTA**

PACKAGING / VERPAKUNG / OPAKOWANIE / BALENÍ
- 25 kg

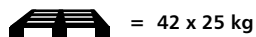

CONSUMPTION / VERBRAUCH / ZUŻYCIE / SPOTŘEBA
- 5-9 kg/m²

COLOR / FARBTÖNE / ODCIENIE / ODSTÍNY

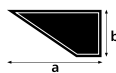
**GROUT BAG / FUGENSACK / TORBA DO FUGOWANIA / SPÁROVACÍ PYTEL**

a = 59 mm / b = 330

STONESIL AQUA - WATER-REPELLENT / FINALSHUTZ / HYDROFOBIZATOR / HYDROFOBIZANT

for STONE VENEER / für VERBLENDSTEINEZ / pro KAMENNÉ OBKLADY

PACKAGING / VERPACKUNG / OPAKOWANIE / BALENÍ
- 1 l

10 x 1 l = 

CONSUMPTION / VERBRAUCH / ZUŻYCIE / SPOTŘEBA
- 1 l/7m²



WILDSTONE HP - DEEP PRIMER / TIEFENGRUND GRUNDIERUNG / GRUNT / HLOUBKOVÁ PENETRACE

PACKAGING / VERPACKUNG / OPAKOWANIE / BALENÍ
- 1 l

10 x 1 l = 

CONSUMPTION / VERBRAUCH / ZUŻYCIE / SPOTŘEBA
- 1 l/7m²



**WILDSTONE PN - DISPERSIVE COATING / ADHÄSIONSBRÜCKE FÜR UNTERGRÜNDE
POWŁOKA DYSPEZYJNA / ADHEZNÍ MŮSTEK**

PACKAGING / VERPACKUNG / OPAKOWANIE / BALENÍ
- 3 l

CONSUMPTION / VERBRAUCH / ZUŻYCIE / SPOTŘEBA
- 1 l/3-7m²



EKOSTONE - WAXCOATING / WACHSANSTRICH / POWŁOKA WOSKOWA / OCHRANNÝ NÁTĚŘ

for PAVEMENT / für PFLASTER / dla BRIK / na DLAŽBU

PACKAGING / VERPACKUNG / OPAKOWANIE / BALENÍ
- 1 l

9 x 1 l = 

CONSUMPTION / VERBRAUCH / ZUŻYCIE / SPOTŘEBA
- 1 l/10m²



APLIKACE KAMENNÉHO OBKLADU NA ZATEPLOVACÍ SYSTÉM THERMAL INSULATION SYSTEM WITH WILD STONE VENEER STONE WÄRMEDÄMMSYSTEM MIT WILD STONE VERBLENDSTEINE SYSTEM OCIEPLEŃ Z UŻYCIEM KAMIENIA LICOWEGO WILD STONE

DETAIL ZÁKLADNÍ SKLADBY – SVISLÝ ŘEZ

- ❶ Zdivo
- ❷ Lepicí hmota: Baumit StarContact
- ❸ Izolační výrobek:
Desky z expandovaného polystyrenu: EPS 120F
fasádní, EPS 100F fasádní
- ❹ Hmota pro vytváření základní vrstvy: Baumit
StarContact
- ❺ Skleněná síťovina:
Baumit KeraTex – Vertex R 275 A101
- ❻ Hmoždinky:
hmoždinky s kovovým trnem:
Ejotherm STR U 2G/fischer
Termoz CS 8
- ❼ Hmota pro lepení obkladu:
WILD STONE LM
- ❽ Lehčený kamenný obklad WILD STONE
- ❾ Spárovací hmota: WILD STONE SH
- ❿ Hydrofobní nástřik STONESIL AQUA

DETAIL OF BASIC COMPOSITION – VERTICAL SECTION

- ❶ Masonry
- ❷ Adhesive: Baumit StarContact
- ❸ Insulation product:
Expanded polystyrene boards: EPS 120F facade
EPS 100F facade
- ❹ Base layer material: Baumit StarContact
- ❺ Glass mesh: Baumit KeraTex – Vertex R 275 A101
- ❻ Dowels:
dowels with a metal pike:
Ejotherm STR U 2G/fischer
Termoz CS 8
- ❼ Adhesive: WILD STONE LM
- ❽ Lightweight stone cladding WILD STONE
- ❾ Grout: WILD STONE SH
- ❿ Water-repellent STONESIL AQUA

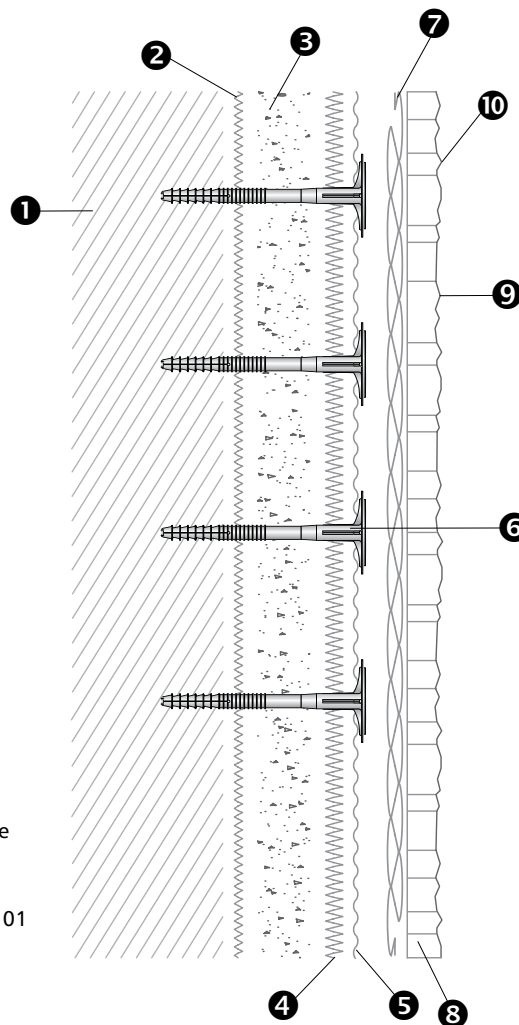

GRUNDAUFBAU-DETAILS – VERTIKALER SCHNITT

- ❶ Mauerwerk
- ❷ Klebemasse: Baumit StarContact
- ❸ Isolationsprodukt:
Platten aus expandiertem Polystyren: EPS 120F
Fassade, EPS 100F Fassade
- ❹ Masse für Schaffung der Grundsicht:
Baumit StarContact
- ❺ Glasgeflecht:
Baumit KeraTex – Vertex R 275 A101
- ❻ Dübel: Dübel mit Metalldorn:
Ejotherm STR U 2G/fischer Termoz CS 8
- ❼ Kleber WILD STONE LM
- ❽ Verblendsteine WILD STONE
- ❾ Fugenmasse: WILD STONE SH
- ❿ Wasserabweisender Anstrich STONESIL AQUA

DETAL PODSTAWOWEJ STRUKTURY – PRZEKRÓJ PIONOWY

- ❶ Mur
- ❷ Klej: Baumit StarContact
- ❸ Wyrób izolacyjny: Płyty ze styropianu:
EPS 120F, EPS 100F elewacyjne
- ❹ Zaprawa do wytworzenia podkładu:
Baumit StarContact
- ❺ Siatka szklana:
Baumit KeraTex – Vertex R 275 A101
- ❻ Kołki do styropianu:
Kołki z trzpieniem metalowym:
Ejotherm STR U 2G/fischer
Termoz CS 8
- ❼ Klej WILD STONE LM
- ❽ Kamień dekoracyjny WILD STONE
- ❾ Fugowanie WILD STONE SH
- ❿ Powlekanie STONESIL AQUA

APLIKACE KAMENNÉHO OBKLADU NA CIHLOVÉ ZDIVO THE APPLICATION OF VENEER STONE ON BRICKWORK ANWENDUNG VOM VERBLENDSTEINE AUF ZIEGELMAUERWERK MONTAŽ KAMIENI DEKORACYJNYCH NA MURZE

DETAIL ZÁKLADNÍ SKLADBY – SVISLÝ ŘEZ

- ❶ Cihlové zdivo
- ❷ Cementová omítka
(dle situace možno vynechat)
- ❸ Nanopenetrace WILD STONE HP
- ❹ Lepidlo WILD STONE LM
- ❺ Obkladový kámen WILD STONE
- ❻ Spárovací hmota WILD STONE SH
- ❼ Náštřík STONESIL AQUA

DETAIL OF BASIC COMPOSITION – VERTICAL SECTION

- ❶ Brickwork
- ❷ Cement facing (de situation - can be omitted)
- ❸ Disperse coating WILD STONE HP
- ❹ Adhesive WILD STONE LM
- ❺ Veneer stone WILD STONE
- ❻ Grouting WILD STONE SH
- ❼ Water-repellent STONESIL AQUA

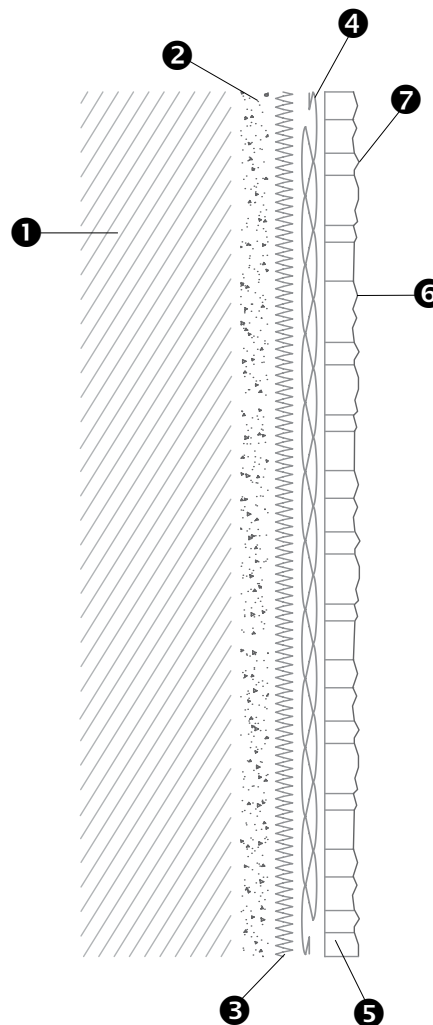

GRUNDAUFBAU-DETAILS – VERTIKALER SCHNITT

- ❶ Ziegelmauerwerk
- ❷ Zementputz (je nach Situation -
kannweggelassen werden)
- ❸ Grundierung WILD STONE HP
- ❹ Kleber WILD STONE LM
- ❺ Verblendsteine WILD STONE
- ❻ Verfugung WILD STONE SH
- ❼ Wasserabweisender Anstrich
STONESIL AQUA

DETAL PODSTAWOWEJ STRUKTURY – PRZEKRÓJ PIONOWY

- ❶ Mur
- ❷ Tynk cementowy
- ❸ Grunt WILD STONE HP
- ❹ Klej WILD STONE LM
- ❺ Kamień dekoracyjny
- ❻ Fugowanie WILD STONE SH
- ❼ Powlekanie STONESIL AQUA

APLIKACE KAMENNÉHO OBKLADU NA DESKY FERMACELL – ODVĚTRANÁ FASÁDA INSTALATION OF VENEER STONE ON FERMACELL POWERPANEL VERLEGUNG VON VERBLENDSTEINE AUF FERMACELL POWERPANELLE KLEJENIE PŁYTEK KAMIENNYCH NA FERMACELL – FASADA WENTYLOWANA

DETAIL ZÁKLADNÍ SKLADBY – SVISLÝ ŘEZ

- 1 Zdivo
- 2 Tepelná izolace (dle situace možno vynechat)
- 3 Konzola/profil DEKMETAL
- 4 Difuzně otevřená fólie
- 5 EPDM páska
- 6 Deska FERMACELL Powerpanel H₂O + šrouby
- 7 Nanopenetace WILD STONE HP
- 8 Adhezní můstek WILD STONE PN
- 9 Hmota pro lepení obkladu: WILD STONE LM
- 10 Obkladový kámen WILD STONE
- 11 Spárovací hmota WILD STONE SH
- 12 Hydrofobní nástřík STONESIL AQUA

Info: Desky FERMACELL se mezi sebou lepí spárovacím lepidlem Fermacell.

Výrobci a dodavatelé si vyhrazují právo změny na základě konkretizací podkladů či zjištěných skutečností, případně technologických změn.

DETAIL OF BASIC COMPOSITION – VERTICAL SECTION

- 1 Masonry
- 2 Thermal insulation (de situation – can be omitted)
- 3 Support profiles DEKMETAL
- 4 Damp proof membrane
- 5 EPDM tape
- 6 FERMACELL power panel H₂O + screws
- 7 Primer WILD STONE HP
- 8 Dispersive coating WILD STONE PN
- 9 Adhesive WILD STONE LM
- 10 Veneer stone WILD STONE
- 11 Grouting WILD STONE SH
- 12 Water-repellent STONESIL AQUA

Info: FERMACELL boards are glued together with Fermacell grouting adhesive.

The manufacturers and suppliers reserve the right to make changes based on specifics of the materials or facts or technological changes.

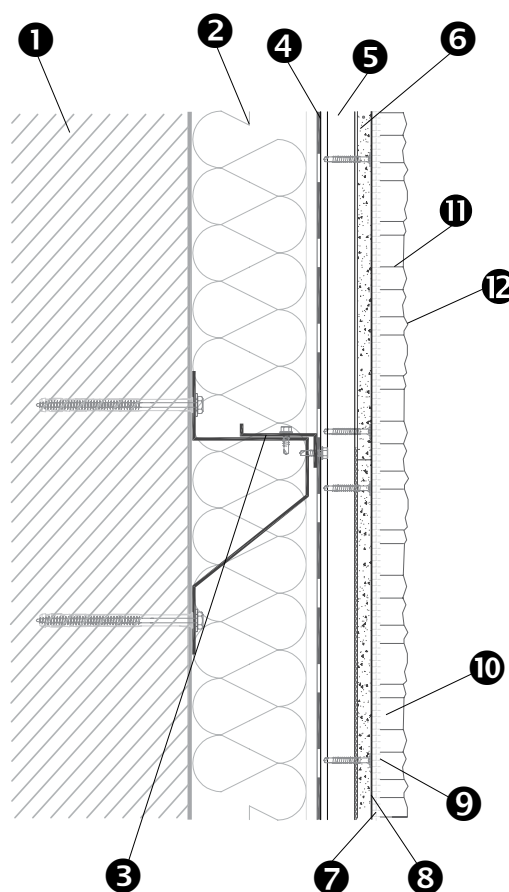

GRUNDAUFBAU-DETAILS – VERTIKALER SCHNITT

- 1 Mauerwerk
- 2 Wärmedämmung (je nach situation – kann weggelassen werden)
- 3 Profile DEKMETAL
- 4 Dampfsperrfolie
- 5 EPDM-Klebeband
- 6 Fermacell powerpanel H₂O + Schrauben
- 7 Grundierung WILD STONE HP
- 8 Adhäsionsbrücke WILD STONE PN
- 9 Kleber WILD STONE LM
- 10 Verblendsteine WILD STONE
- 11 Verfugung WILD STONE SH
- 12 Wasserabweisender Anstrich STONESIL AQUA

Infos: FERMACELL-Platten werden mit Fermacell-Fugenkleber verklebt.

Die Hersteller und Lieferanten behalten sich das Recht vor, Änderungen vorzunehmen, die sich aus den Besonderheiten der Materialien oder aus technischen Änderungen ergeben.

DETAL PODSTAWOWEJ STRUKTURY – PRZEKRÓJ PIONOWY

- 1 Mur
- 2 Izolacja termiczna (w zależności od sytuacji – może być pominięta)
- 3 profile DEKMETAL
- 4 Folia otwarta dyfuzyjnie
- 5 Taśma EPDM
- 6 FERMACELL powerpanell płyta + śruby
- 7 Grunt WILD STONE HP
- 8 Powłoka dyspersyjna WILD STONE PN
- 9 Klej WILD STONE LM
- 10 Kamień dekoracyjny WILD STONE
- 11 Fugowanie WILD STONE SH
- 12 Powlekanie STONESIL AQUA

Info: Płyty FERMACELL są klejone za pomocą kleju Fermacell.

Producenci i dostawcy zastrzegają sobie prawo do wprowadzania zmian na podstawie specyfiki materiałów lub faktów lub zmian technologicznych.

APLIKACE KAMENNÉHO OBKLADU NA SÁDROKARTON INSTALATION OF VENEER STONE ON PLASTERBOARD VERLEGUNG VON WANDVERBLENDER AUF GIPSKARTONPLATTEN KLEJENIE PŁYTEK KAMIENNYCH DO PŁYT GIPSOWYCH

DETAIL ZÁKLADNÍ SKLADBY – SVISLÝ ŘEZ

- ❶ Zdivo
- ❷ Hliníkový nosný profil
- ❸ Sádrokartonová deska + šrouby
- ❹ Nanopenetace WILD STONE HP
- ❺ Síťování + WILD STONE LM
- ❻ Vruty + hmoždinky do sádrokartonu
- ❼ Lepidlo WILD STONE LM
- ❽ Obkladový kámen WILD STONE
- ❾ Spárovací hmota WILD STONE SH
- ❿ Hydrofobní nástřik STONESIL AQUA

DETAIL OF BASIC COMPOSITION – VERTICAL SECTION

- ❶ Masonry
- ❷ Aluminium support profiles
- ❸ Plasterboards + screws
- ❹ Primer WILD STONE HP
- ❺ Fiberglass mesh + WILD STONE LM
- ❻ Screws + dowels for plasterboard
- ❼ Adhesive WILD STONE LM
- ❽ Veneer stone WILD STONE
- ❾ Grouting WILD STONE SH
- ❿ Water-repellent STONESIL AQUA

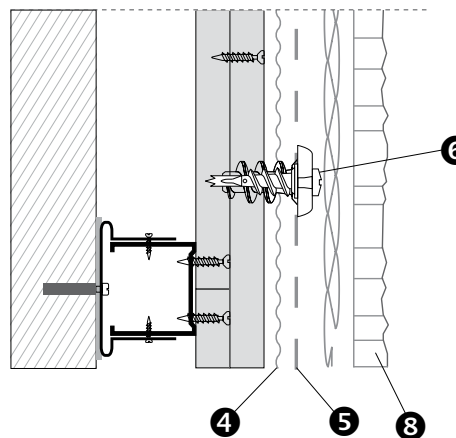
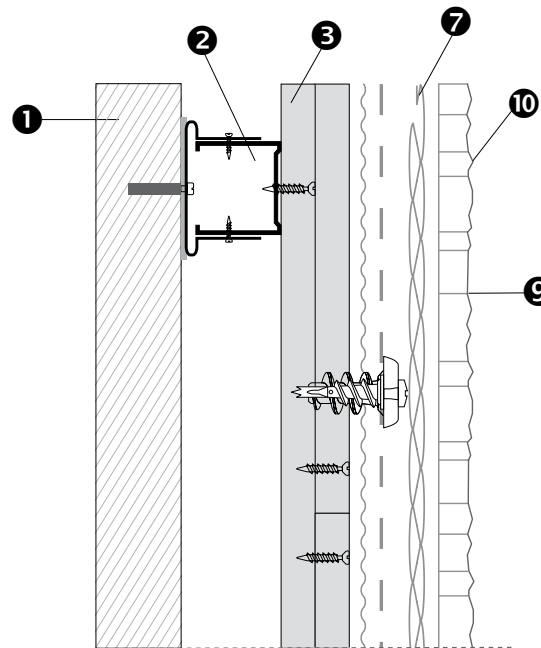

GRUNDAUFBAU-DETAILS – VERTIKALER SCHNITT

- ❶ Mauerwerk
- ❷ Aluminiumprofile für Gipskartonplatten
- ❸ Gipskartonplatten + Schrauben
- ❹ Grundierung WILD STONE HP
- ❺ Gewebe + WILD STONE LM
- ❻ Schrauben + Dübel
- ❼ Kleber WILD STONE LM
- ❽ Verblendsteine WILD STONE
- ❾ Verfugung WILD STONE SH
- ❿ Wasserabweisender Anstrich STONESIL AQUA

DETAL PODSTAWOWEJ STRUKTURY – PRZEKRÓJ PIONOWY

- ❶ Mur
- ❷ Aluminiowy profil nośny
- ❸ Płyta regipsowa + śruby
- ❹ Grunt WILD STONE HP
- ❺ Siatka z włókna szklanego + WILD STONE LM
- ❻ Śruby + kotwienie
- ❼ Klej WILD STONE LM
- ❽ Kamień dekoracyjny WILD STONE
- ❾ Fugowanie WILD STONE SH
- ❿ Powlekanie STONESIL AQUA

LEPENÍ NA ŽELEZOBETONOVOU ZEĎ INSTALATION OF VENEER STONE ON REINFORCED CONCRETE WALL VERLEGUNG VON VERBLENDSTEINE AUF EINER STAHLBETONWAND KLEJENIE DO ŚCIANY ŻELBETOWEJ

DETAIL ZÁKLADNÍ SKLADBY – SVISLÝ ŘEZ

- ❶ Mechanicky zbrúšená železobetónová zeď
- ❷ Nanopenetrace WILD STONE HP
- ❸ Adhezní můstek WILD STONE PN
- ❹ Hmota pro lepení obkladu WILD STONE LM
- ❺ Lehčený kamenný obklad WILD STONE
- ❻ Spárovací hmota: WILD STONE SH
- ❼ Hydrofobní nástřik STONESIL AQUA

DETAIL OF BASIC COMPOSITION – VERTICAL SECTION

- ❶ Mechanically ground reinforced concrete wall
- ❷ Primer WILD STONE HP
- ❸ Dispersive coating WILD STONE PN
- ❹ Adhesive WILD STONE LM
- ❺ Veneer stone WILD STONE
- ❻ Grouting WILD STONE SH
- ❼ Water-repellent STONESIL AQUA

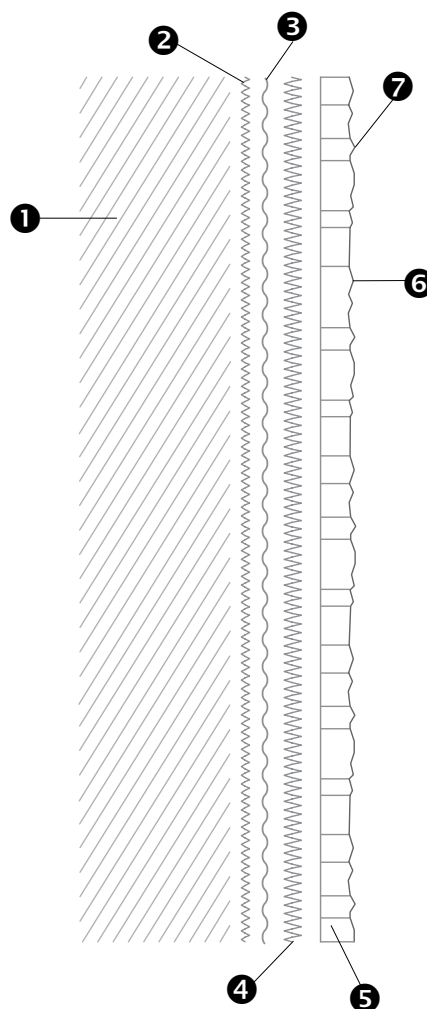

GRUNDAUFBAU-DETAILS – VERTIKALER SCHNITT

- ❶ Mechanisch geschliffene Stahlbetonwand
- ❷ Grundierung WILD STONE HP
- ❸ Adhäsionsbrücke WILD STONE PN
- ❹ Kleber WILD STONE LM
- ❺ Verblendsteine WILD STONE
- ❻ Verfugung WILD STONE SH
- ❼ Wasserabweisender Anstrich STONESIL AQUA

DETAL PODSTAWOWEJ STRUKTURY – PRZEKRÓJ PIONOWY

- ❶ Ściana żelbetowa szlifowana mechanicznie
- ❷ Grunt WILD STONE HP
- ❸ Powłoka dyspersyjna WILD STONE PN
- ❹ Klej WILD STONE LM
- ❺ Kamień dekoracyjny WILD STONE
- ❻ Fugowanie WILD STONE SH
- ❼ Powlekanie STONESIL AQUA

APLIKACE KAMENNÉHO OBKLADU NA ZATEPLOVACÍ SYSTÉM THERMAL INSULATION SYSTEM WITH WILD STONE VENEER STONE WÄRMEDÄMMSYSTEM MIT WILD STONE VERBLENDSTEIN SYSTEM OCIEPLEŃ Z UŻYCIEM KAMIENIA LICOWEGO WILD STONE

DETAIL ZÁKLADNÍ SKLADBY – SVISLÝ ŘEZ

- 1 Zdivo
- 2 Lepicí hmota:
Weber.therm elastic LZS 720 (Z), LZS 730
- 3 Izolační výrobek:
Desky z minerální vlny: MW (TR80) desky s kolmou orientací vláken – lamela
- 4 Hmota pro vytváření základní vrstvy:
Weber.therm elastic LZS 720
- 5 Skleněná síťovina:
2x VERTEX R 131 A101 (dvě vrstvy) (160 g/m²)
2x weber.therm 131 (dvě vrstvy)
1x VERTEX R 267 A101 (jedna vrstva) (314 g/m²)
- 6 Hmoždinky:
BRAVOLL PTH-S/EJOTHERM STR U/EJOTHERM STR U 2G/KOELNER TFIX-8S
- 7 Hmota pro lepení obkladu:
WILD STONE LM (W)/weber.xerm862
- 8 Lehčený kamenný obklad WILD STONE
- 9 Spárovací hmota: WILD STONE SH
- 10 Hydrofobní nástřik STONESIL AQUA

DETAIL OF BASIC COMPOSITION – VERTICAL SECTION

- 1 Masonry
- 2 Adhesive:
Weber.therm elastic LZS 720 (Z), LZS 730
- 3 Insulation product:
Mineral wool boards: MW (TR80) boards with perpendicular fiber orientation – lamella
- 4 Base layer material:
Weber.therm elastic LZS 720
- 5 Glass mesh:
2x VERTEX R 131 A101 (two layers) (160 g/m²)
2x weber.therm 131 (two layers)
1x VERTEX R 267 A101 (one layer) (314 g/m²)
- 6 Dowels: BRAVOLL PTH-S/EJOTHERM STR U/EJOTHERM STR U 2G/KOELNER TFIX-8S
- 7 Adhesive: WILD STONE LM (W)/weber.xerm862
- 8 Lightweight stone cladding WILD STONE
- 9 Grout: WILD STONE SH
- 10 Hydrophobic spray STONESIL AQUA

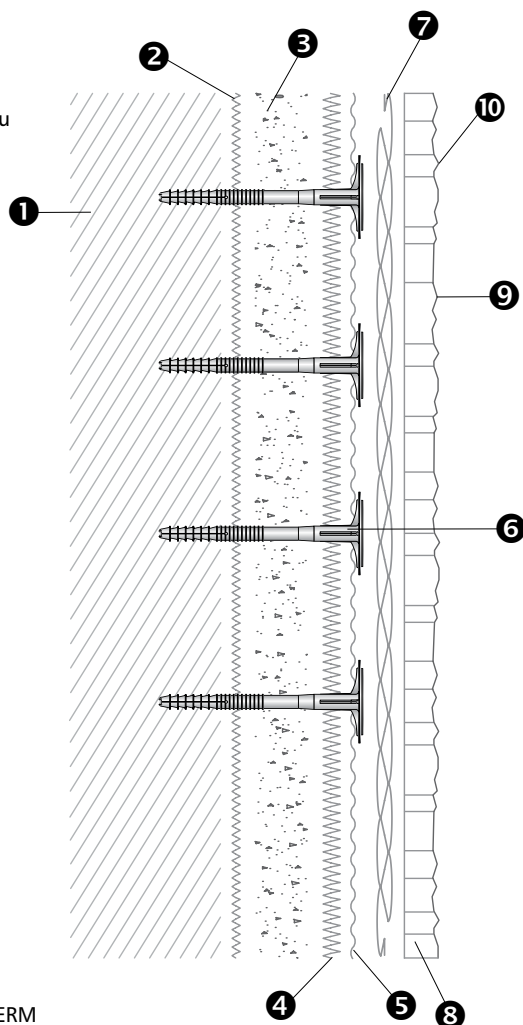

GRUNDAUFBAU-DETAILS – VERTIKALER SCHNITT

- 1 Mauerwerk
- 2 Klebemasse:
Weber.therm elastic LZS 720 (Z), LZS 730
- 3 Isolationsprodukt:
Mineralwollplatten: MW (TR80) Platten mit senkrechter Faserorientierung – Lamelle
- 4 Masse für Schaffung der Grundsicht:
Weber.therm elastic LZS 720
- 5 Glasgeflecht:
2x VERTEX R 131 A101 (zwei Schichten) (160 g/m²)
2x weber.therm 131 (zwei Schichten)
1x VERTEX R 267 A101 (eine Schicht) (314 g/m²)
- 6 Dübel: BRAVOLL PTH-S/EJOTHERM STR U/EJOTHERM STR U 2G/KOELNER TFIX-8S
- 7 Kleber: WILD STONE LM (W)/weber.xerm862
- 8 Verblendsteine WILD STONE
- 9 Fugenmasse: WILD STONE SH
- 10 Wasserabweisender Anstrich STONESIL Aqua

DETAL PODSTAWOWEJ STRUKTURY – PRZEKRÓJ PIONOWY

- 1 Mur
- 2 Klej: Weber.therm elastic LZS 720 (Z), LZS 730
- 3 Wyrób izolacyjny:
Płyty z wełny mineralnej: Płyty MW (TR80) z orientacją pionową włókna – lamelowe
- 4 Zaprawa do wytworzenia podkładu:
Weber.therm elastic LZS 720
- 5 Siatka szklana:
2x VERTEX R 131 A101 (dwie warstwy) (160 g/m²)
2x weber.therm 131 (dwie warstwy)
1x VERTEX R 267 A101 (jedna warstwa) (314 g/m²)
- 6 Kołki do styropianu:
BRAVOLL PTH-S/EJOTHERM STR U/EJOTHERM STR U 2G/KOELNER TFIX-8S
- 7 Zaprawa do klejenia okładziny
WILD STONE LM (W)/weber.xerm862
- 8 Lekka okładzina kamienna WILD STONE
- 9 Zaprawa do fugowania: WILD STONE SH
- 10 Powłoka hydrofobowa STONESIL AQUA





LABORATORY TESTS / LABORTESTS / TESTY LABORATORYJNE / LABORATORNÍ TESTY









UNIKA[®]
NATURSTEINWERK
5211 Lengau
Steinmetzmeisterbetrieb
Tel.: +43 (0)7746-2061
www.natursteine.at